

Coca-Cola Zero

Brand Identity and Design Standards

v1.0

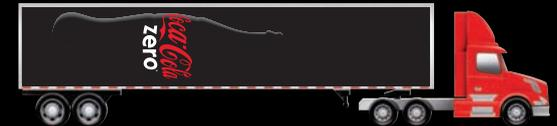

Contents

Please note that updates to the Brand Identity and Design Standards will only be made once per year.

Strategic Overview.....	1.0
Identity Standards: Core Brand Elements and Standards.....	2.0
Packaging Design Standards	3.0
Point-of-Sale Design Standards	4.0
Equipment Design Standards.....	5.0
Signage Design Standards	6.0
Fleet Design Standards	7.0
Trademark Usage Requirements	8.0
Identity Standards Management Team and Process	9.0

Simply put, the Brand Identity and Design Standards exist to provide clear, reliable and enduring guidance on how to use the Brand Elements and how to design for the Coca-Cola Zero Brand Identity around the world.

The importance of the Brand Standards, however, is anything but utilitarian. They are central to our ongoing commitment to:

1. Maintain authenticity and build Brand equity;
2. Leverage the scale of our System across all markets;
3. Provide more consistency and quality; and
4. Facilitate increased System productivity.

Understanding how the Brand Standards fit into and affect all Brand touchpoints is a precursor to using the Brand Standards. This chapter examines both.

Contents

- What is a Brand Identity? 1.02
- Why Do We Need Identity and Design Standards? 1.03
- Who Should Use These Identity and Design Standards? 1.04
- Identity and Design Standards: Foundation 1.05
- Design Principles 1.06
- Strategic Framework: Overview 1.07
- Strategic Framework: Applied 1.08
- Making the Identity and Design Standards a System-wide Success 1.09

What is a Brand Identity?

A brand identity is the totality of all touchpoints (media, platforms, channels). A brand identity is experienced by those who come into contact with the brand and influences their opinion of that brand.

Central to all touchpoints are the brand's defining – or core – elements, the visual keys to creating an integrated, distinctive and differentiated brand.

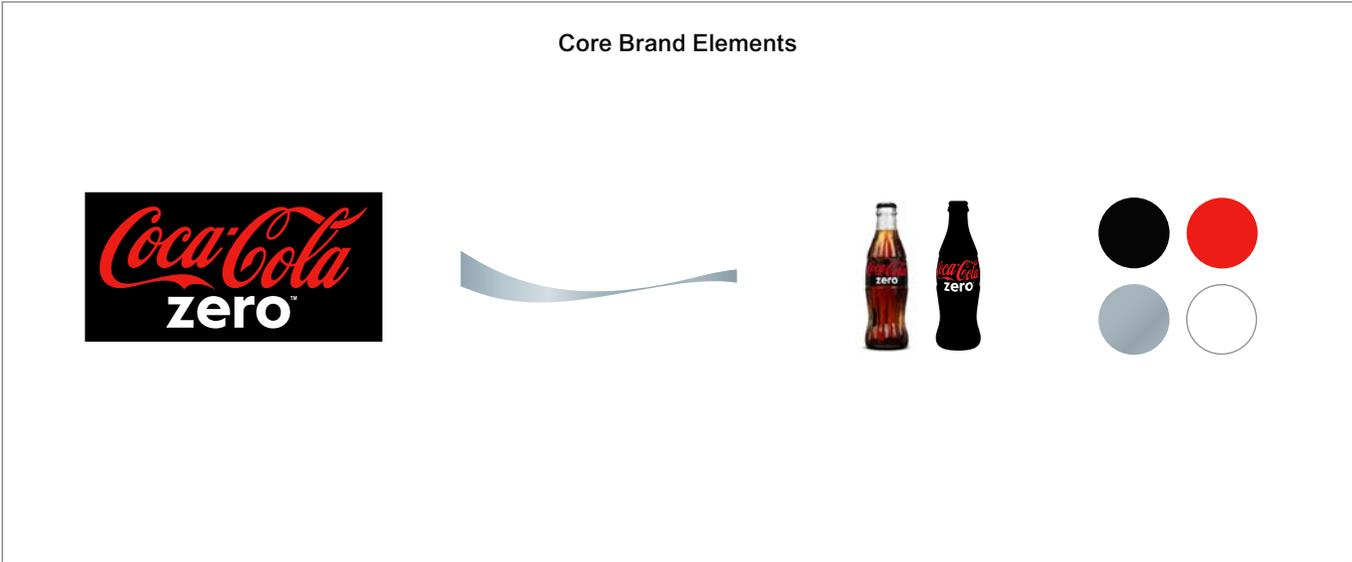

Why Do We Need Identity and Design Standards?

The Coca-Cola Zero Brand Identity is an inextricable part of the Brand's equity and profoundly impacts how consumers experience it. All executions that utilize Coca-Cola Zero are part of the Brand Identity, as they are what consumers see and associate with Coca-Cola Zero.

System-wide Identity and Design Standards are a longstanding part of our heritage and essential to building strong global Brands. They empower markets to build from universal rules and conventions so that the Brand Identity is experienced consistently worldwide on a daily basis and protected across every touchpoint.

The Identity and Design Standards Better Position the Company to:

1. Maintain Authenticity and Build Equity

Both are crucial to reinforcing and increasing the relevance of the Brand to our consumers. The better we represent the Brand, the better we can increase mindshare and protect the Brand Identity from dilution.

2. Leverage the Scale of our System Across All Markets

We have an exceptional System in place around the globe; Identity and Design Standards provide equally exceptional and efficient means to leverage it for greater consistency and speed to market.

3. Provide More Consistency and Quality Across the System

The higher our System-wide consistency and efficiencies, the stronger the connection that consumers draw from all they see and hear, creating more inherent value in the Coca-Cola Zero Brand to benefit the entire System.

4. Facilitate Increased System-wide Productivity

Consistencies achieved through System-wide Standards allow for longer-lasting materials and potential reuse, thus saving time and money.

Who Should Use These Identity and Design Standards?

The short answer is: anyone who activates anything for the Brand Coca-Cola Zero.

More specifically, the Brand Standards should be used by all Company functions and the Bottling System, as well as all partners, agencies and other parties involved in any Coca-Cola Zero touchpoint.

Always use the latest version of the Brand Standards available on the Coca-Cola Zero Brand Identity and Design Standards website.

Always make sure partners, agencies and third parties have the latest version of the Brand Standards. Before they can obtain access, all third parties must agree to keep the Brand Standards confidential.

In addition, be sure to seek local guidance for:

- Compliance with local legal regulations and mandates;
- Local legal approval of all materials prior to use in the marketplace; and
- Alignment of the communication objectives for your market and/or Brands.

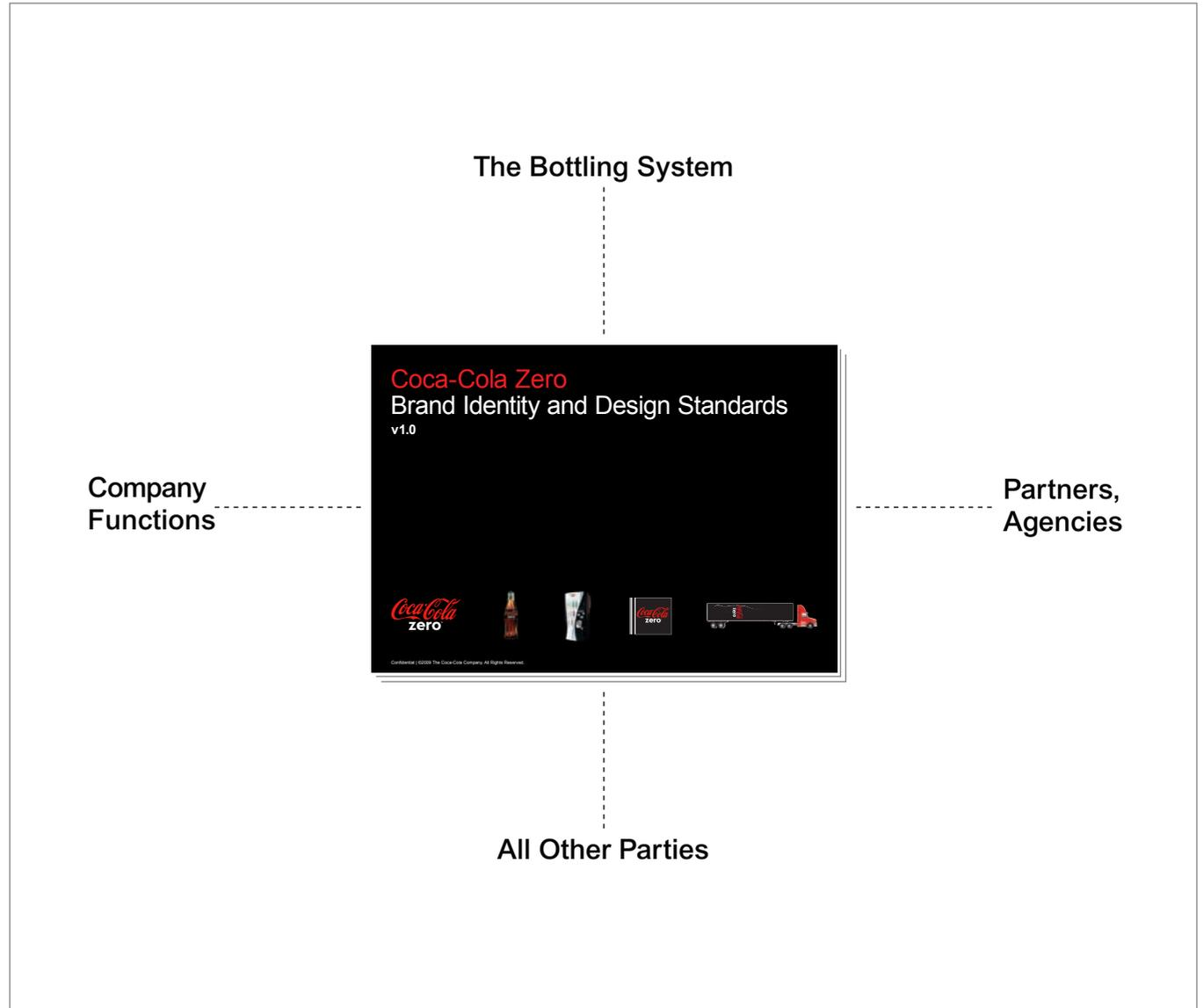

Identity and Design Standards: Foundation

As with all expressions of the Brand, the Identity and Design Standards align with the Coca-Cola Zero Brand Vision and Architecture (BVA), as shown here.

The Coca-Cola Zero Brand is positioned to target 18-24 year old males who are fueled by an unprecedented belief in what they can achieve, and driven by an impatience with the status quo. Coca-Cola Zero speaks to individuals who are in their formative years of change and discovery, and who are actively taking the lead in determining who they can be.

Always refer to SparkCity for the most recent version of the BVA.

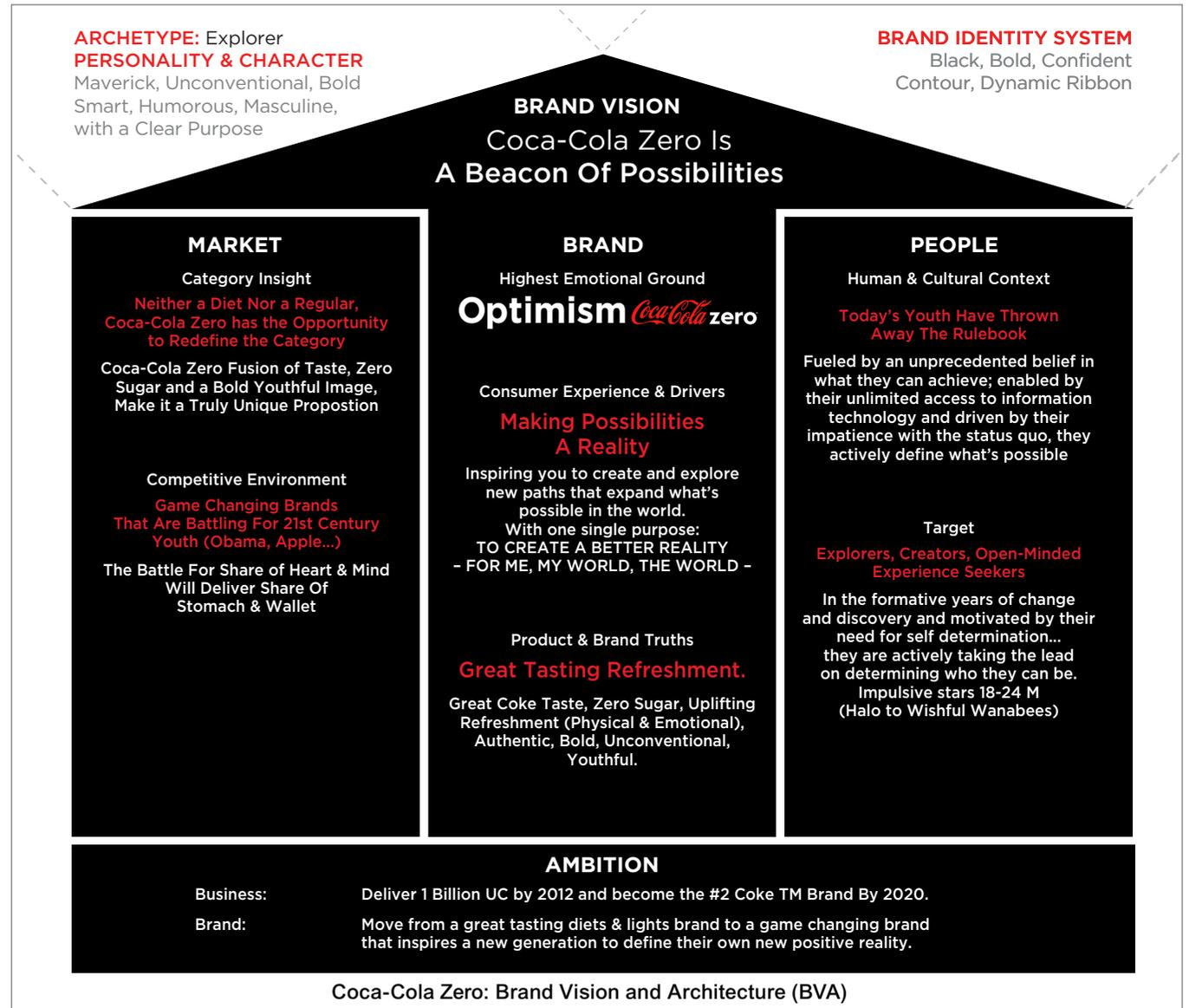

Design Principles

The Coca-Cola Zero Design Principles help to focus and clarify what is – and is not – Coca-Cola Zero.

These Principles drive the design of all touchpoints for the Coca-Cola Zero Brand.

Apply these Principles whenever new executions are created. Everything that has anything to do with the Brand must align with them.

The Coca-Cola Zero Design Principles

1. Bold Simplicity

A return to clarity; removal of all extraneous noise and static around the Brand to find the bold, simple essence of Coca-Cola zero.

2. Real and Genuine

Driven by self-determination, Coke Zero defines a unique path to a greater destiny in a style that is true to self.

3. Own Black

At every touch point, we will leverage the bold and confident vitality of Coke Zero Black around the world. Additionally, we will continue to integrate the thread of Red into everything we do.

4. Bold and Unexpected

Coca-Cola Zero displays its maverick character in an unpredictable journey of discovery. Coke Zero has license to explore new paths and expand what's possible.

Strategic Framework: Overview

The Strategic Framework is the means by which we ensure the Brand Identity is experienced consistently by consumers and protected at every touchpoint.

1. The BVA, Design Principles and Identity Standards are part of the Coca-Cola Zero Brand. Everything created for the Brand ensues from them. The preceding page reviews the Design Principles.
2. The Design Standards further define and articulate Identity Standards for all Brand executions in categories such as Packaging, POS and Equipment.
3. All work done across the Brand should directly leverage Tier 1 and Identity Standards. It should also refer to the Design Standards for touchpoints that are covered in depth there.

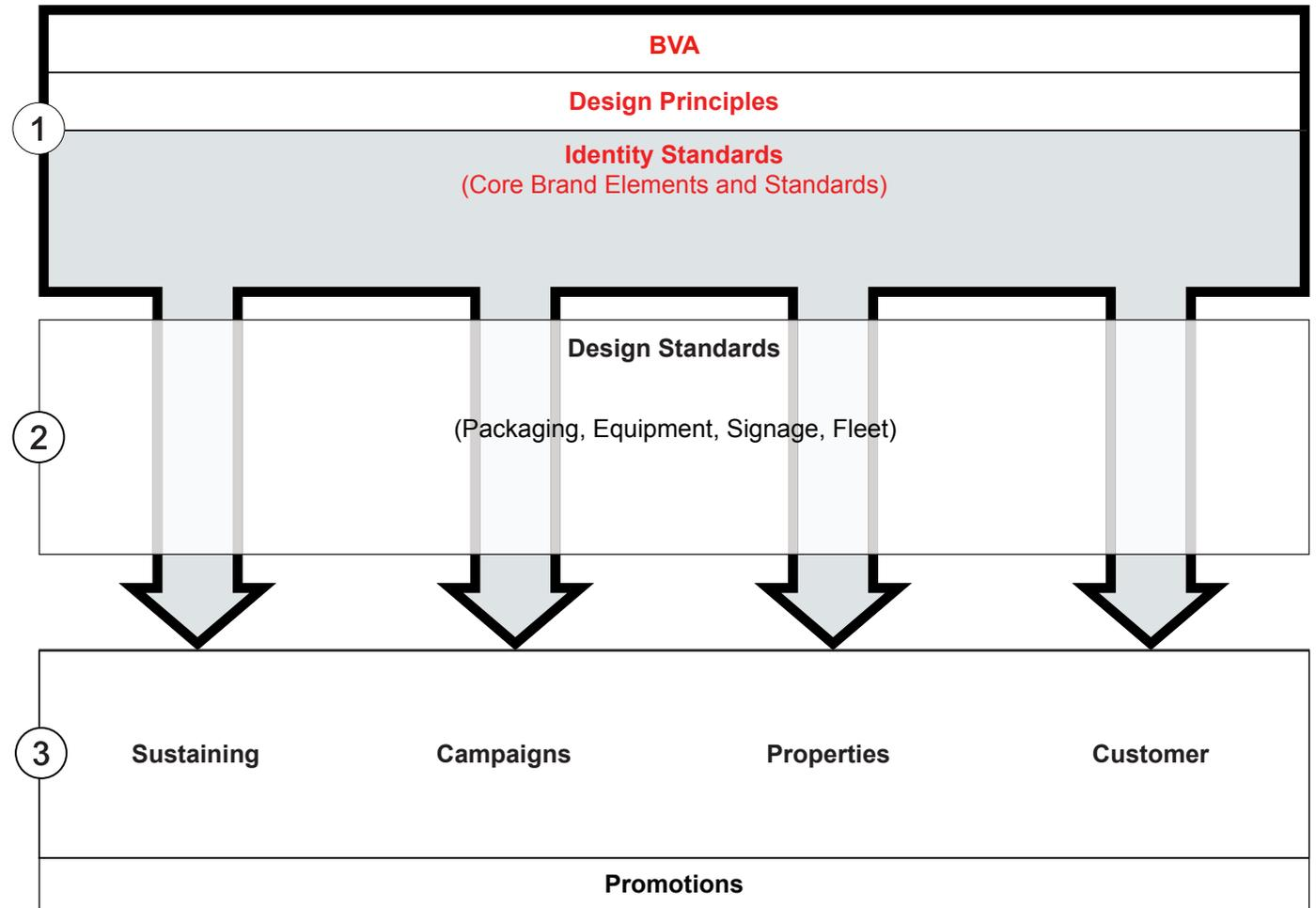

Strategic Framework: Applied

1. The BVA, Design Principles and Identity Standards are part of the Coca-Cola Zero Brand. Everything created for the Brand ensues from them.
2. The Design Standards further define and articulate Identity Standards for all Brand executions in categories such as Packaging, POS and Equipment.
3. All work done across the Brand should directly leverage Tier 1 and Identity Standards. It should also refer to the Design Standards for touchpoints that are covered in depth there.

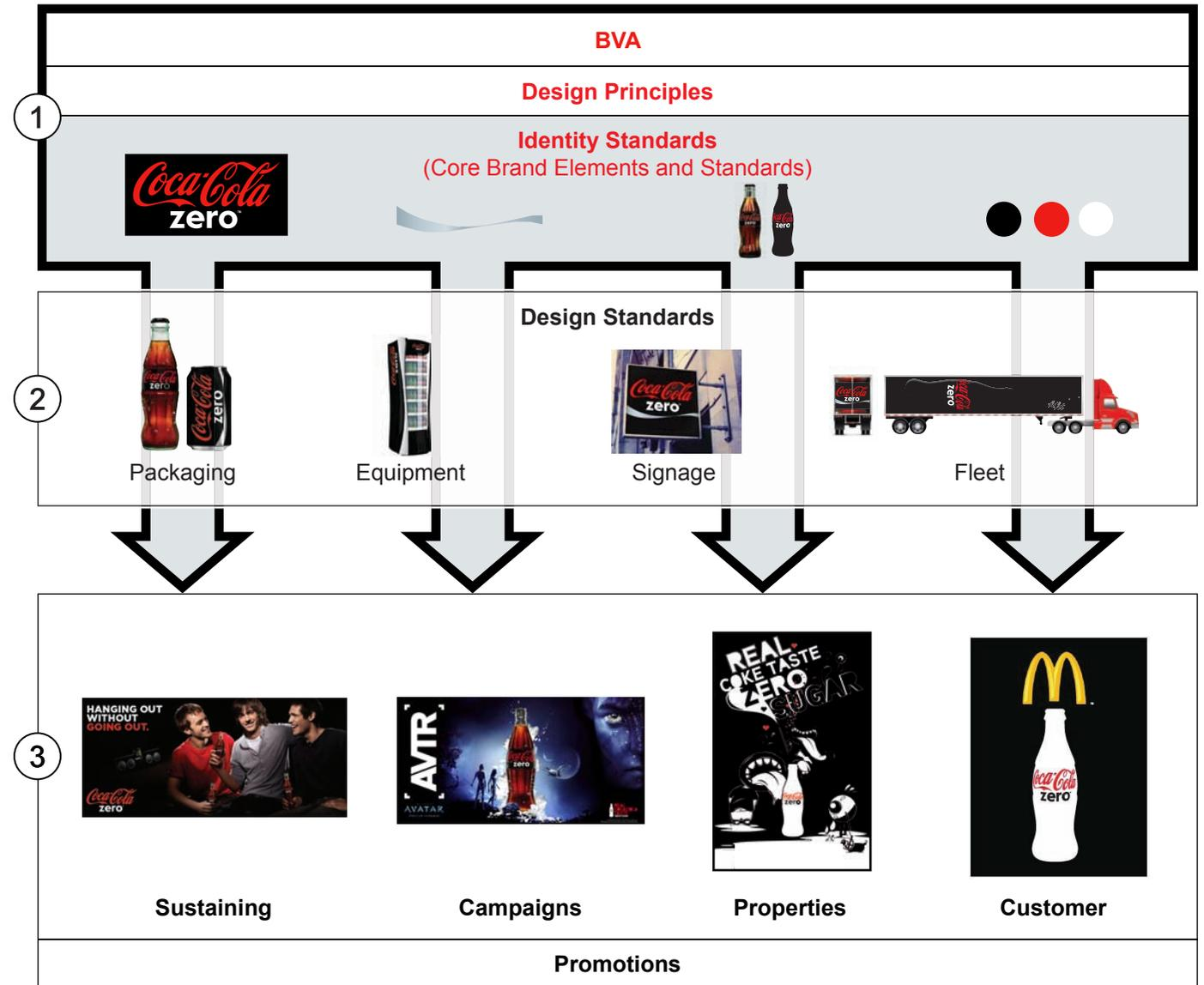

Making the Identity and Design Standards a System-wide Success

- Always consult the Identity and Design Standards before embarking on new work. It is each individual's responsibility to ensure that all work is created in compliance with the Brand Standards.
- Ensure that any agency or partner who is working on or creating something for the Brand has reviewed and understands how the Identity and Design Standards relate to their work. Agencies and partners should only access the Brand Standards if they have entered into a confidentiality agreement with The Coca-Cola Company.
- Refer often to Chapter 2.0, Core Brand Elements and Standards. This chapter reviews in detail the proper usage of these building blocks of Brand-authentic and consistent designs, setting the stage for using all other chapters in the Brand Standards.
- Consult chapters 3.0 – 7.0 for specific information on Graphics Application across the main touchpoints of the Brand – including, for the first time, guidance on Proprietary Form for Packaging and Equipment.
- Careful and thorough review of the Brand Standards should answer most if not all questions that typically arise in the course of creating and producing work. Should circumstances necessitate a request for specialized guidance or an exception, the protocol described in the Identity Standards Management Team and Process chapter (9.0) must be followed.
- All advertising materials shown in this document are for purposes of illustrating the Brand Standards. None of them can be used in the marketplace unless they are reviewed and approved by your local legal counsel.
- See the Contents page for a complete list of topics in this document and their locations. Main chapters include:
 - 1.0 Strategic Overview
 - 2.0 Identity Standards: Core Brand Elements and Standards
 - 3.0 Packaging Design Standards
 - 4.0 Point-of-Sale Design Standards
 - 5.0 Equipment Design Standards
 - 6.0 Signage Design Standards
 - 7.0 Fleet Design Standards
 - 8.0 Trademark Usage Requirements
 - 9.0 Identity Standards Management Team and Process

Identity Standards: Core Brand Elements and Standards

2.0

Contents

Overview	2.02	Backgrounds: Flat Colors	2.37
Coca-Cola Zero Logo	2.03	Product Photography Art Direction	2.38
Colors	2.04	Contour Glass Bottle Photography	2.39
Clear Space, Minimum Size, ® Scaling	2.05	Photography Details	2.40
Don'ts	2.06	Cans, PETs, Other Packaging.....	2.41
Horizontal Limited Use	2.07		
Horizontal Safe Area	2.08		
Lock-up Specifications	2.09		
20° Angled Logo	2.10		
20° Safe Area	2.11		
20° Cropping & Position	2.12		
Lock-up Specifications	2.13		
Horizontal Limited Use	2.14		
Horizontal Safe Area	2.15		
Contour Bottle Symbol	2.16		
Contour Bottle Symbol with Coca-Cola Zero Logo	2.17		
Colors	2.18		
Clear Space, Safe Area	2.19		
Minimum Size	2.20		
Dynamic Ribbon	2.23		
Cropping	2.24		
Colors, Usage	2.25		
Lock-up Specifications	2.26		
Don'ts	2.28		
Arden Square	2.29		
Colors	2.30		
Clear Space, Minimum Size	2.31		
Don'ts	2.32		
Color Palette	2.33		
Don'ts	2.34		
Typography	2.35		
Headlines and Body Copy	2.36		
Don'ts	2.37		

Overview

Core Brand Elements are the building blocks of the Brand Identity and Design Standards. These simple and timeless elements play an inextricable role in portraying and protecting our Brand across all touchpoints.

Consistently using a common set of elements enables integrated marketing communications, innovation and maximum System scale. It is therefore essential that any work for the Coca-Cola Zero Brand be approached in a manner that:

- Faithfully applies the Identity Standards for the Core Brand Elements, while
- Reinforcing the Design Principles (reviewed in the Strategic Overview Chapter 1.0).

This chapter provides an overview of each Core Brand Element – heritage, equity, relevance – and standards for using them.

Approved digital files of the Core Brand Elements, customizable graphics and design templates for Packaging, POS and Equipment are available on the Design Machine website at www.coca-coladesignmachine.com. Please use only the approved versions supplied there.



Coca-Cola Zero Logo

The Coca-Cola Zero Logo is the primary asset for the Coca-Cola Zero Brand and is the preferred Logo to represent this Brand.

The Spencerian Script, carried over from the Coca-Cola Brand, is visually locked together with the “Zero” Logo, which is designed to express the bold confidence and masculinity of the Brand. Together they form a holistic representation of the Coca-Cola Zero Brand that reflects the heritage of the original Coca-Cola Trademark.

The Spencerian Script that is used for the Coca-Cola Trademark should never be used for anything other than the trademarks incorporating “Coca-Cola” and “Coke,” as well as the trade names of The Coca-Cola Company, its subsidiaries and its Bottlers.

We are committed to using the Coca-Cola Zero Logo in its purest original form. By boldly using the Script and “Zero” lockup on its own or in combination with other elements, we can create executions that retain the true essence of the Coca-Cola Brand, yet fashions an enduring and unique vision for the Coca-Cola Zero Brand.

Use only the approved versions of the Coca-Cola Zero Logo available on the Design Machine website.



Colors

- Color executions of the Coca-Cola Zero Logo include the standard Logo on a white background and the reversed Logo in Coke Red and white on a black background only, as described at right.
- The Coca-Cola Zero Logo must never be shown in other colors, even if they are within the Brand color palette.
- The Coca-Cola Zero Logo must never be shown on backgrounds other than those shown here.

Exceptions

- For media in which color is not an option (e.g., a black-and-white print ad), use either the restricted-use Coca-Cola Zero Logo or the restricted-use reverse Coca-Cola Zero Logo described at right.
- For premiums, architectural details or other applications where the Coca-Cola Zero Logo is etched, embossed, sandblasted or spot varnished, the color can be the same as the substrate of the material used.



Standard Coca-Cola Zero Logo
Coke Red and black on a white background.



Reversed Coca-Cola Zero Logo
Coke Red and white on a black background.



Restricted-use Coca-Cola Zero Logo
Black on a white background.



Restricted-use Reversed
Coca-Cola Zero Logo
Reversed from a black background.

Clear Space, Minimum Size, TM Scaling, Cropping

Clear Space

Surround the Coca-Cola Zero Logo with clear space that is, at a minimum, “hyphen height” – i.e., equal to the height of the hyphen connecting “Coca” and “Cola.”

Minimum Print Size

- For the Coca-Cola Zero Logo: at least 15.875 mm (.625 inches) wide.
- For the TM: at least 1 mm (.04 inches) in diameter.

Minimum Onscreen Size

- Display the Coca-Cola Zero Logo at least 100 pixels wide and the TM at least 6 pixels in diameter.
- Always view PDFs of the Brand Standards at 100% for proper reference.

TM Scaling

- Align the top edge of the TM with the top of the “o” in “Zero.”
- When using the Coca-Cola Zero Logo in smaller sizes, scale up the TM as needed to ensure legibility. Always scale the TM from the top edge.
- Make sure the clear space between the TM and the end of the “o” in “Zero” equals at least 1/4 of the diameter of the TM and that it is no further away than one full diameter of the TM.

Cropping

- The Coca-Cola Zero Logo must not be cropped in any permanent executions, such as signage, vending or fleet.
- In the case of temporary executions, exceptions to this rule may be granted if the market is considered mature from a Brand equity perspective. Exceptions are meant to have a maximum life of 3 months in market and each exception should only happen once a year. Refer to the Identity Standards Management Team and Process chapter (9.0) for more information on submitting exception requests.



Clear Space = h Distance



Minimum Print Size



Minimum Onscreen Size



TM Scaling (Coca-Cola Zero Logo)

Don'ts



Do not use any other version of the Coke Logo. This includes variants in existing Brand Elements or lock-ups.



Do not remove or reposition the TM.



Do not add elements.



Do not add glows to the Coca-Cola Zero Logo.



Do not add strokes or outlines to the Coca-Cola Zero Logo.



Do not scale/resize the Coca-Cola Zero Logo disproportionately.



Do not rotate the Coca-Cola Zero Logo, except for 2° counter clockwise rotations.



Do not skew the Coca-Cola Zero Logo or create false perspectives.



Do not distort the Coca-Cola Zero Logo.



Do not use unspecified colors.



Do not enlarge Zero separately.



Do not reduce zero separately.



Do not create a black disk icon.



Do not place on any color other than black.

Horizontal Limited Use

To the right is a single line, horizontal version of the Coca-Cola Zero Logo which has been specifically designed with limited use in mind.

Primarily, this version of the Coca-Cola Zero Logo should be used for shelf-strips, or in a horizontal format where space is limited and maximum impact is required.

The black background shown in Ref. 2 is preferred. Your choice of Coca-Cola Zero Logo (Ref. 1 & 2) should be made based upon the application - visibility and legibility should always be maintained.

The Coca-Cola Zero Logo Lock-up should not be altered.

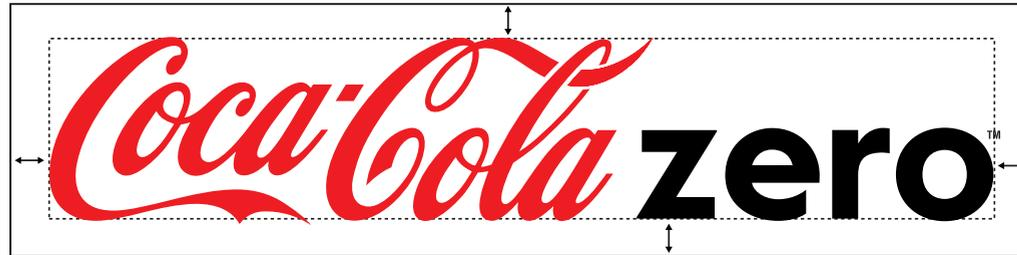

1.



2.



3.



4.

Horizontal Safe Area

The minimum required clear space for the Coke Zero Horizontal Logo is equal to the height of the hyphen located between "Coca" and "Cola."



Lock-up Specifications

Apply the standards below when pairing the Coca-Cola Zero Logo with the logo of another company for co-branding and partnership purposes.

A legal line is a statement appearing in footnote form in an advertisement or on packaging that indicates the identity of the trademark owner. Generally, legal lines are recommended although no longer required for use on packaging, advertisements, POS and promotional materials for TCCC products when those are the only product trademarks depicted in the materials. However, if TCCC trademarks are depicted with trademarks for third party products, then use of a legal line is required. Please consult the Trademark Usage Requirements chapter (8.0) for further information.

Horizontal Lock-ups

- The Coca-Cola Zero Logo must always sit to the left of the other logo.
- The clear space distance between the Coca-Cola Zero Logo and the other logo must be equal to 6 times the height of the hyphen connecting “Coca” and “Cola.” This clear space area is shown to the right as ‘6 h.’
- The clear space begins at the end of the flourish of the capital “C” in “Cola” and terminates at the leftmost edge of the other logo.
- A black vertical rule must bisect the clear space between the two logos.
- The height of the vertical rule must equal the height of the Coca-Cola Zero Logo; i.e., the distance from the baseline of the Coca-Cola Zero Logo to top edge of the capital “C” in “Cola.”
- The baseline of the other logo must always sit even with the baseline of the Coca-Cola Zero Logo.
- The size height of the other logo must never exceed the height of the Coca-Cola Zero Logo.

Vertical Lock-ups

- The Coca-Cola Zero Logo must always sit above the other logo.
- The clear space distance between the Coca-Cola Zero Logo and the logo beneath it must be equal to 6 times the height of the hyphen connecting “Coca” and “Cola.” This clear space area is shown to the right as ‘6 h.’
- A black horizontal rule must bisect the clear space between the two logos.
- The width of the horizontal rule must equal the distance from the leftmost edge of the capital “C” in Coca to the rightmost edge of the flourish of the capital “C” in “Cola.”
- The other logo must be centered directly beneath the center point of the Coca-Cola Zero Logo, as shown in the illustration at right.
- The size height of the other logo must never exceed the height of the Coca-Cola Zero Logo.

Consider the overall effect of the pairing of the Coca-Cola Zero Logo and the other logo when adjusting the size of the latter. If the Coca-Cola Zero Logo seems in any way overpowered by the other logo, reduce the size of the latter until a balanced pairing is achieved.

Horizontal Lock-up



Vertical Lock-up



20° Angled Logo

This 20° angled Logo should only be used on temporary materials.

The black background shown in Ref. 2 is preferred. Your choice of Logo (Ref. 1 & 2) should be made based upon the application.

– Visibility and legibility should always be maintained. Please see application examples for guidance.



1. 20 Degrees.



2.



3.



4.

20° Safe Area

The minimum required clear space for the Coca-Cola Zero Logo is equal to the height of the hyphen located between “Coca” and “Cola.”



20° Cropping & Position

The Coca-Cola Zero Logo Lock-up and positions shown below are the 2 primary placements for the Logo to sit when not contained within the Contour Bottle.

The Coca-Cola Zero Logo should be cropped off 2 edges as shown.

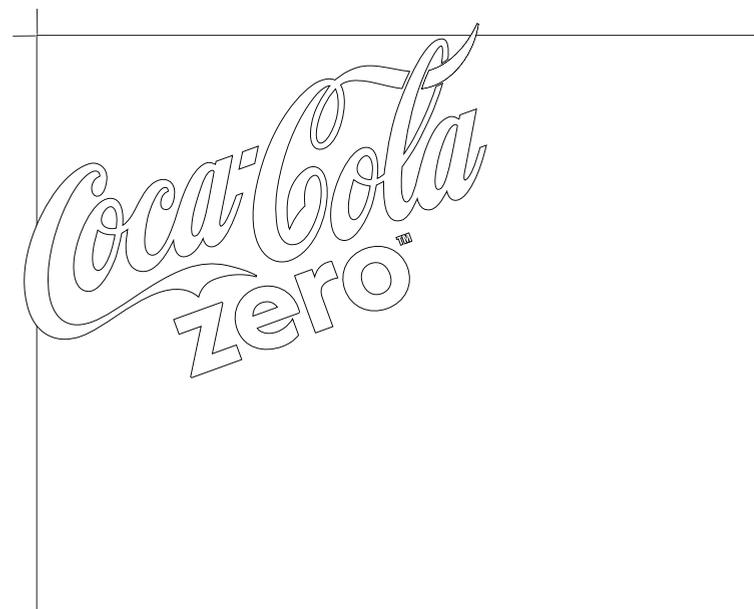
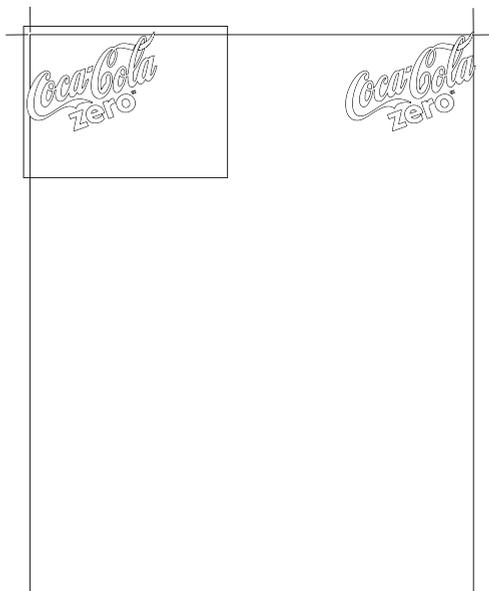

Clear Space, Minimum Size, ® Scaling, Cropping

Clear Space

Surround the Coke Zero Logo with clear space that is, at a minimum, equal to the width of the top of the “k” in “Coke.”

Minimum Print Size

- For the Script: at least 15.875 mm (.625 inches) wide.
- For the TM: at least 1 mm (.04 inches) in diameter.

Minimum Onscreen Size

- Display the Script at least 100 pixels wide and the TM at least 6 pixels in diameter.
- Always view PDFs of the Brand Standards at 100% for proper reference.

® Scaling

- Align the top edge of the TM with the top of the “o” in “Zero.”
- When using the Zero in smaller sizes, scale up the TM as needed to ensure legibility. Always scale the TM from the top edge.
- Make sure the clear space between the TM and the end of the “o” in “Zero” equals at least 1/4 of the diameter of the TM and that it is no further away than one full diameter of the TM.

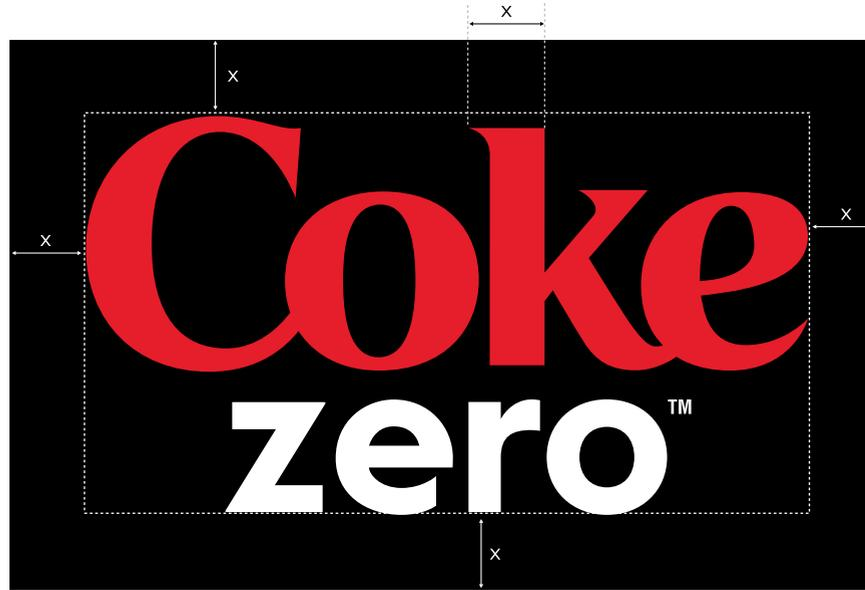

Clear Space = x Distance



Minimum Print Size



Minimum Onscreen Size



TM Scaling (Coca-Cola Zero Logo)

Horizontal Limited Use

At right is a single line, horizontal version of the Coke Zero Logo which has been specifically designed with limited use in mind.

Primarily, this version of the Logo should be used for shelf-strips, or in a horizontal format where space is limited and maximum impact is required.

Your choice of Logo (Ref. 1 & 2) should be made based upon the application - visibility and legibility should always be maintained.

The Coke Zero Logo should not be altered.



1.



2.



3.



4.

Horizontal Safe Area

The minimum required clear space for the Coke Zero Horizontal Logo is equal to the height of the half-circle formed inside the top of "e" in "Zero."



Contour Bottle Symbol

Designed in 1915, the Contour Bottle symbolizes Coca-Cola at a glance. This primary element of Brand language carries such strong emotional resonance and universal recognition that it is second in the world only to one other iconic trademark: the Coca-Cola Zero Logo.

The Contour Bottle's memorable curvilinear form, inspired by the shape of a cocoa-bean pod, is so iconic that it can be identified by silhouette or touch alone.

Legendary industrial designer Raymond Loewy described the Contour Bottle as "a masterpiece" and "...one of the classics of packaging history." Celebrated works by artists such as Warhol and Rauschenberg reflect the Contour Bottle's indelible role as a cultural icon.

The Contour Bottle remains one of our most modern yet timeless expressions of the uplifting experience of drinking a Coke.

The Brand Standards include the two expressions of the Contour Bottle shown here. The bold simplicity of the Contour Bottle Symbol makes it an ideal choice for many touchpoints, including those where photography is not appropriate or necessary.

Proper use of the Contour Bottle Symbol is addressed on the following pages. Refer to the Photography Art Direction section of this chapter regarding the proper use of the Contour Bottle Photo.

Use only the approved versions of the Contour Bottle Symbol available on the Design Machine website.



Contour Bottle Photo

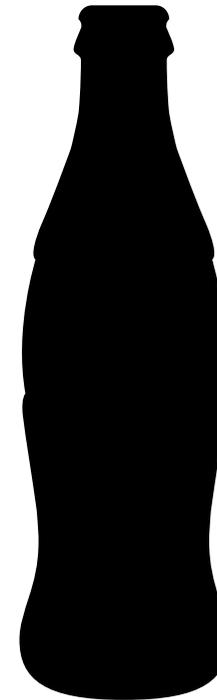

Contour Bottle Symbol

Contour Bottle Symbol with Coca-Cola Zero Logo Usage

The Contour Bottle Symbol with the 3D Coca-Cola Zero Logo is the standard for the Brand.

- The 3D Coca-Cola Zero Logo expresses the true curvature of the Contour Bottle.
- Never use the 3D Coca-Cola Zero Logo elsewhere than on the Contour Bottle Symbol.
- Never use a 2D Coca-Cola Zero Logo.
- If an International Variant of the Coca-Cola Zero Logo is the primary communication of the Brand for a market, it must be adapted to be consistent with the standard 3D form.
- Keep the shape, proportions, positioning and Lock-up of the Coca-Cola Zero Logo exactly as shown in the Brand Standards.
- On a black Contour Bottle Symbol, the Spencerian Script is Coke Red and “Zero” is white.
- On a white Contour Bottle Symbol, the Spencerian Script is Coke Red and “Zero” is black.
- No other colors, even if they’re in the Brand color palette, are to be used.

Exception

For certain executions (e.g., Campaigns and Properties), the shape of the Contour Bottle Symbol can be formed by illustrations surrounding it. However, illustrations are not permitted inside the shape of the Contour Bottle Symbol.

Caveats

- The shape of the Contour Bottle Symbol must always remain the same.
- The Contour Bottle Symbol must always be shown in its entirety and never be cropped.



Colors

Show the Contour Bottle Symbol as either:

- Black on a white background, or
- White on a black background.

Caveat

- The Contour Bottle Symbol must never be shown in other colors, even if they're in the Brand color palette.

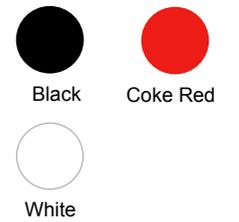

Clear Space, Safe Area

Clear Space

Surround the Contour Bottle Symbol with clear space that is, at a minimum, the x-height of the “o” in “Cola.” This clear space area is shown at right as ‘x.’

The Contour Bottle Symbol must always be shown in its entirety and never be cropped.

Safe Area

The safe area is only relevant for the Contour Bottle Symbol’s position within the page; elements can surround it for other executions.

Clear Space Exception

Clear space can be omitted at the top for certain applications, such as fountain cups and stadium boardings. Do, however, keep the minimum clear space along the sides.



Clear Space



Safe Area

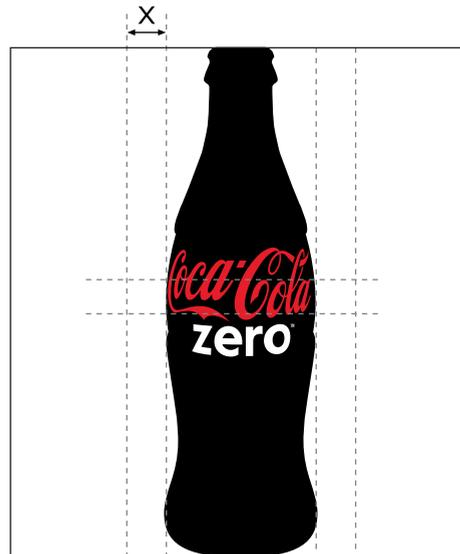

Clear Space Exception

Minimum Size

- Do not scale the Contour Bottle Symbol below these minimal sizes.

Exception

If an execution necessitates using a Contour Bottle Symbol slightly below minimum size, use only the version without the Script. The Script must never be shown smaller than these minimum sizes in order to assure legibility.

- Always view PDFs of the Brand Standards at 100% for proper reference.

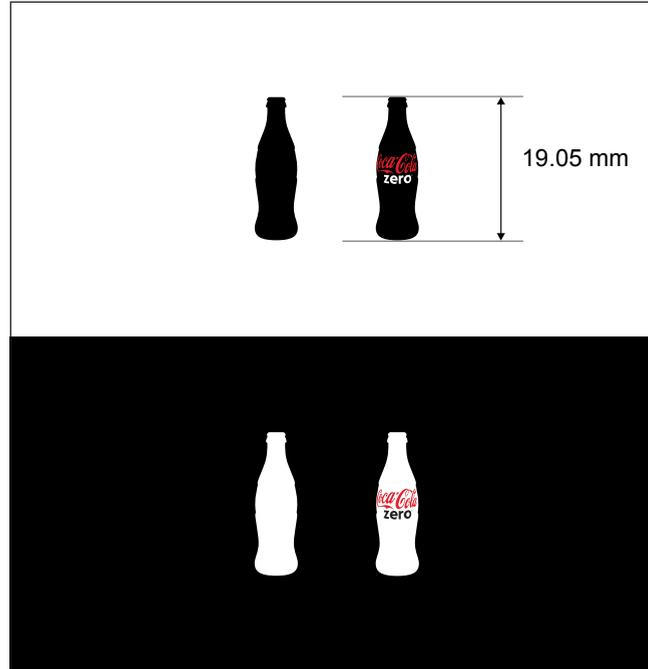

Minimum Print Size
19.05 mm (.75 inches) high.

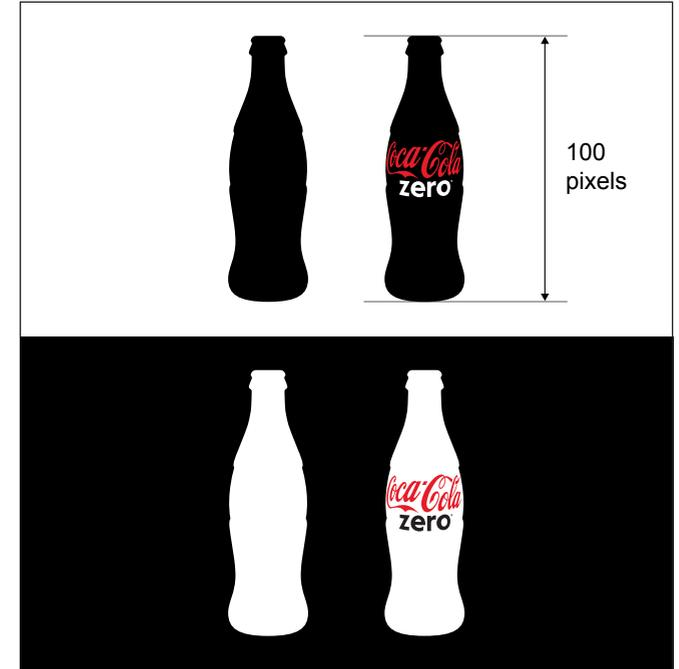

Minimum Onscreen Size
100 pixels high.

Don'ts



Do not use an older version of the Contour Bottle Symbol. This includes variants in existing Brand Elements.



Do not add drop shadows or patterns behind the Contour Bottle Symbol.



Do not add strokes or outlines to the Contour Bottle Symbol.



Do not remove or separate the elements of the Contour Bottle Symbol.



Do not add elements to the Contour Bottle Symbol.



Do not alter the Spencerian Script on the Contour Bottle Symbol.



Do not rotate the Contour Bottle Symbol.



Do not scale/resize the Contour Bottle Symbol disproportionately.



Do not skew the Contour Bottle Symbol or create false perspectives.



Do not distort the Contour Bottle Symbol.



Do not use unspecified colors.



Do not place the Contour Bottle Symbol on unapproved colors.

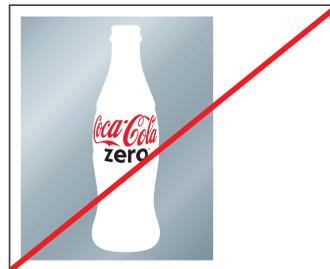

Do not place the Contour Bottle Symbol in enclosing shapes of color (unless they are full-bleed fields of color).



Do not ignore the clear space, alignment or cropping rules for the Contour Bottle Symbol.

Dynamic Ribbon

The Dynamic Ribbon* – often called the Coke “wave” – was introduced to the public in 1970 as part of a new look for Coca-Cola. It is a graphic representation of the space between two Coca-Cola bottles situated side by side.

With its qualities of motion and continuity, the Dynamic Ribbon can be used to:

- Suggest “infinite flow” by spanning layouts.
- Provide balance to layouts containing more surprising Brand Elements.
- Serve as a powerful connecting device not only between Elements, but across executions.

In the hierarchy of Brand Elements, the Dynamic Ribbon follows the Coca-Cola Zero Logo and Contour Bottle Symbol. While this distinctive Element is familiar to some, its meaning and relationship to the Coca-Cola Zero Brand is not always immediate. Keep this in mind when considering use of the Dynamic Ribbon, which is purely optional.

Refer to the following pages and the Trademark Usage Requirements chapter (8.0) for standards specific to the Dynamic Ribbon.

Use only the approved versions of the Dynamic Ribbon available on the Design Machine website.

** While typically known as the Dynamic Ribbon, the legal trademark name is Dynamic Ribbon Device. Consult with your local legal counsel for usage guidance.*



Cropping

- Slight cropping may be necessary because the Dynamic Ribbon needs to bleed off an execution.
- Crop the Dynamic Ribbon evenly, with a maximum of 10% on each side, for executions that have space limitations and when maximum Ribbon impact is necessary.

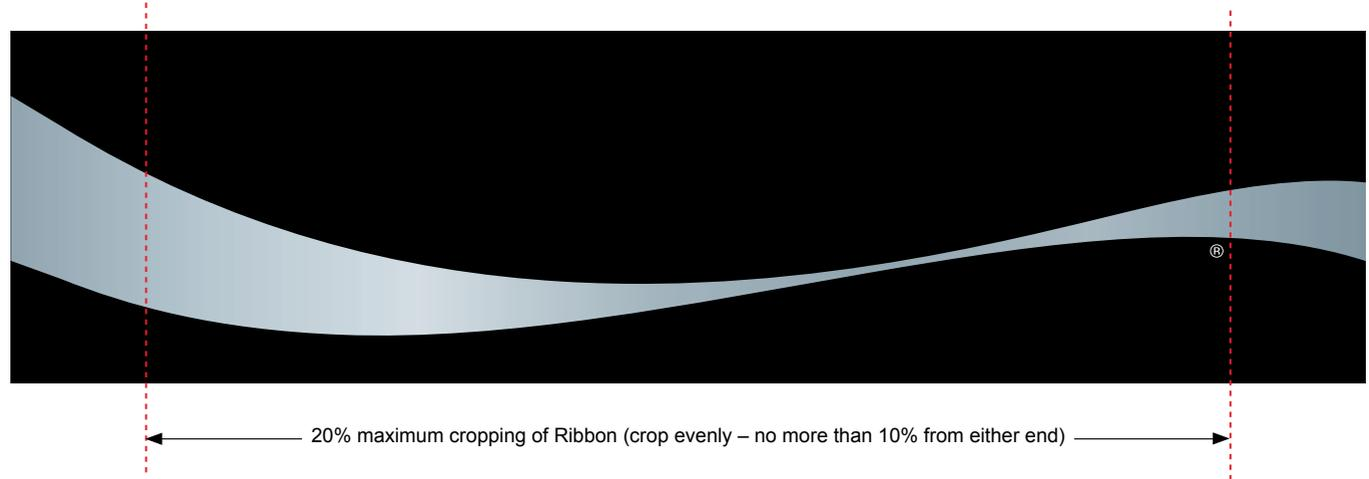

Colors, Usage

Colors

- For sustaining executions, use only silver.
- Do not use patterns or other fill in lieu of the approved solid colors.

Exception

- For media in which color is not an option (e.g., a black-and-white print ad), use the restricted-use Dynamic Ribbon as shown at right.

Usage

- Use the Dynamic Ribbon alone or as a connecting device with other design elements.
- Do not alter the distinctive shape of the Dynamic Ribbon from the approved form as shown in the Brand Standards.
- Do not crop the Dynamic Ribbon more than 10% from either end.
- Do not overlap the Dynamic Ribbon more than 5% when using it with other Brand Elements or graphics.
- Do not cross a section of the Dynamic Ribbon with a design element in a manner that obscures the identifying “thickest-thin-thick” rhythm of its form.
- If approved usage of the Dynamic Ribbon excludes the Coca-Cola Zero Logo, a ® must be included as shown on this page.



Dynamic Ribbon
Silver on a white background.



Restricted-use Dynamic Ribbon
Black on a white background.

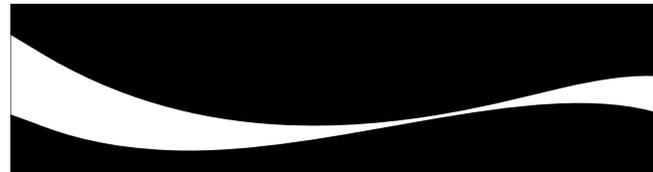

White Dynamic Ribbon
White on a black background.



Silver



White



Black



Dynamic Ribbon
Silver on a white background with ®.

Lock-up Specifications

The Lock-up of the Dynamic Ribbon and Coca-Cola Zero Logo creates a perfectly balanced tension between Brand icons that represent both modernity and heritage.

Space Ratio Between the Coca-Cola Zero Logo and Ribbon

When using the Coca-Cola Zero Logo with the Dynamic Ribbon, the space between the two must be “hyphen height” – i.e., equal to the height of the hyphen connecting “Coca” and “Cola.”

- The Coca-Cola Zero Logo is always centered over the middle of the Dynamic Ribbon.
- The Dynamic Ribbon and the Coca-Cola Zero Logo never overlap.



Space between the Zero and Ribbon = h

Don'ts

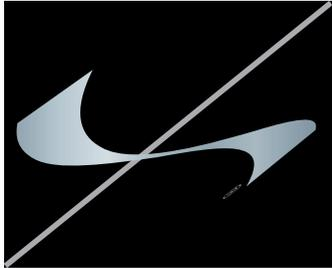

Do not alter or distort the Dynamic Ribbon in any way.



Do not overlap the Dynamic Ribbon in any way with a Brand Element.

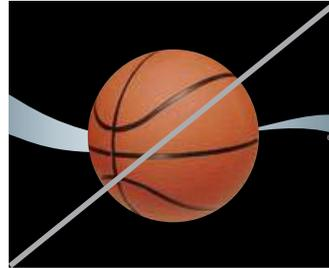

Do not allow design elements to cover more than 5% of the Dynamic Ribbon or obscure its identifying "thickest-thin-thick" rhythm.

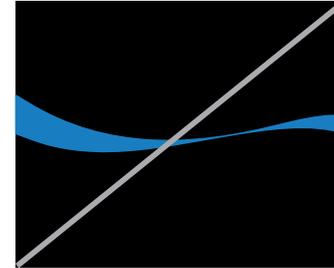

Do not use any colors other than black or white for sustaining executions (Exception: temporary use on Campaigns and with Properties.)

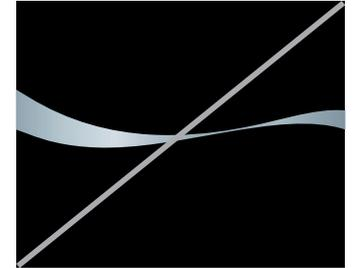

Do not omit the ® from the Dynamic Ribbon if using it without the Coca-Cola Zero Logo.

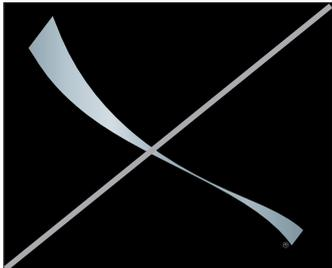

Do not rotate the Dynamic Ribbon, except for 90° counterclockwise rotations.

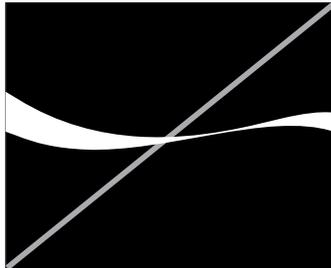

Do not add highlights or drop shadows to the Dynamic Ribbon.

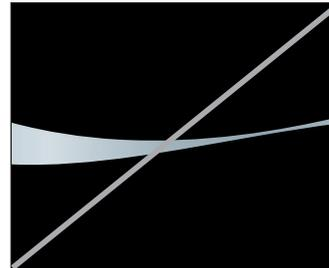

Do not crop the Dynamic Ribbon more than 10% from either end.

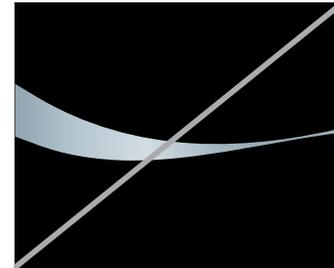

Do not crop Dynamic Ribbon unevenly.

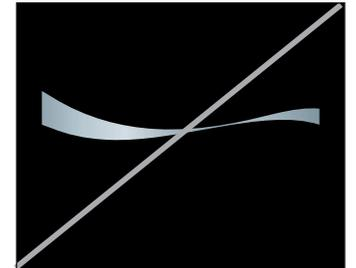

Do not 'float' the Dynamic Ribbon within a design. The only allowable exception is in lock-up executions with the Coca-Cola Zero Logo (i.e., packaging).



Do not alter the proper space ratio for locking up the Dynamic Ribbon and the Coca-Cola Zero Logo.



Do not move the Coca-Cola Zero Logo to an off-center position when creating a lock-up with the Dynamic Ribbon.



Do not alter the standard proportions provided for the Dynamic Ribbon with the Coca-Cola Zero Logo.



Do not use older versions of the Dynamic Ribbon.

Arden Square

The Arden Square is the namesake of designer Elizabeth Arden, who also created the Dynamic Ribbon. It was introduced to the public in 1969.

The original design of the Arden Square was an ingenious blending of three elements distinctive to Coca-Cola: The Spencerian Script, the Dynamic Ribbon and Coke Red. Similarly, the Coca-Cola Zero Brand's Arden Square blends three featured elements: The Coca-Cola Zero Logo, the Dynamic Ribbon and black.

Its exceptional scalability enables bold and simple branding on virtually any medium. In fact, the Coca-Cola Company Arden Square made fashion history in the early 1970's when it was applied in a checkerboard style to bell-bottom pants and other popular items of apparel.

More than thirty years later, the Arden Square is still used to capture consumers' attention, albeit in more traditional applications.

Refer to the following pages for the standards specific to the Arden Square.

Use only the approved versions of the Coca-Cola Zero Arden Square available on the Design Machine website.



Colors

There is only one color execution for the Coca-Cola Zero Arden Square: Coke Red, white and silver on a black background, as shown at right.

Exception

For media in which color is not an option (e.g., a black-and-white print ad), use the restricted-use Arden Square: white on a black background, as shown at far right.



Exception

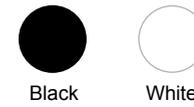

Clear Space, Minimum Size

Clear Space

Surround the Arden Square with clear space that is, at a minimum, the distance from the bottom of the “o” to the top of the “C” in “Coca.” This clear space area is shown at right as ‘x.’

Minimum Print Size

- For the Arden Square: at least 17.767 mm (.6995 inches) wide.
- For the TM: at least 1 mm (.04 inches) in diameter.

Minimum Onscreen Size

- Display the Arden Square at least 112 pixels wide and the ® at least 6 pixels in diameter.
- Always view PDFs of the Brand Standards at 100% for proper reference.

TM Scaling

- Apply the The Coca-Cola Zero Logo TM scaling rules specified on the ‘Clear Space, Minimum Size, TM Scaling, Cropping’ page in this chapter.

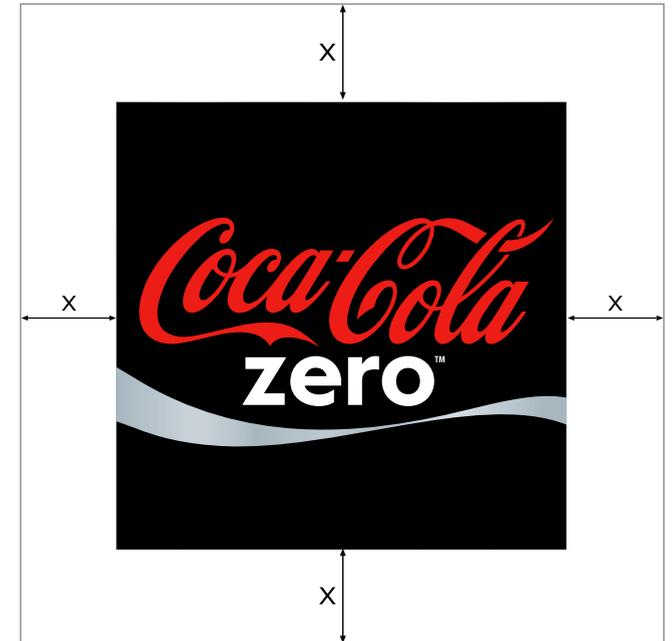
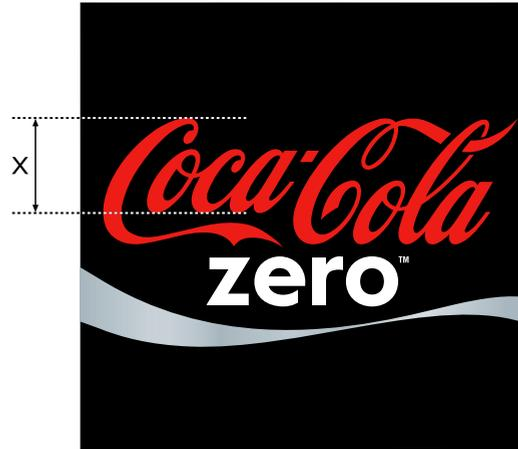

Clear Space = x Distance



Minimum Print Size



Minimum Onscreen Size

Don'ts



Do not use unspecified colors of the Arden Square.



Do not alter the shape or proportions of the Arden Square in any way.



Do not change the placement of the Dynamic Ribbon in the Arden Square.



Do not alter the proper space ratio of the lock-up of the Dynamic Ribbon and the The Coca-Cola Zero Logo.



Do not use an older version of the Arden Square.



Do not use the restricted version of the Arden Square, except as specified on the 'Colors' page in this chapter.



Do not ignore the clear space rules for the Arden Square.

Color Palette

Consumers almost universally identify the very sight of black with Coca-Cola Zero. Remember their mindset when working with the Brand color palette: See black, think Coca-Cola Zero!

4 Primary Brand Colors: Usage

Black must predominate all executions.

Black

- Must appear in all executions in some form: background, Contour Bottle Symbol, et al.
- Must always be the dominant color in an execution.

Coke Red

Use it sparingly to create dynamic framing that empowers the Black communication, keeping it fresh, bold and surprising.

Silver and White

Give top consideration when choosing secondary Brand colors to support the primary Brand colors.

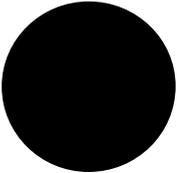
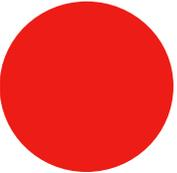
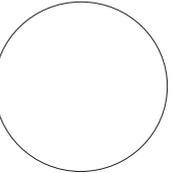
			
Black	Coke Red	Silver	White
PMS = Black	PMS = (no equivalent)	PMS = Opaque White	PMS = Opaque White
C = 0, M = 0, Y = 0, K = 100	C = 4, M = 100, Y = 95, K = 0	C = 0, M = 0, Y = 0, K = 0	C = 0, M = 0, Y = 0, K = 0
R = 0, G = 0, B = 0	R = 244, G = 0, B = 9	R = 255, G = 255, B = 255	R = 255, G = 255, B = 255
Hex = 000000	Hex = F40000		Hex = FFFFFFFF

PMS is a registered trademark of Pantone,® Inc. The colors shown on this page and throughout this document are not intended to match the Pantone Color Standards. For accurate standards, refer to the current edition of the Pantone Color Specifier Guide.

Don'ts

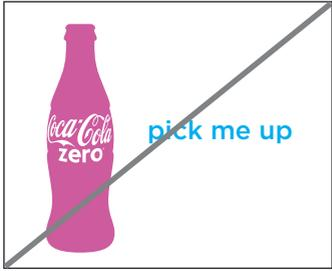

Do not use unapproved colors.



Do not screen or tint the Brand colors.



Do not omit Coke Red from layouts.



Do not create layouts in which black or red are not the dominant colors.



Do not use secondary Brand colors as primary Brand colors.

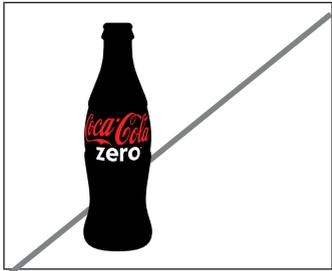

Do not change the specified color breakdowns of the Brand colors.
Do not use breakdowns from previous editions of the Brand Standards.



Do not add gradients or multiple tones of color to the Brand colors.

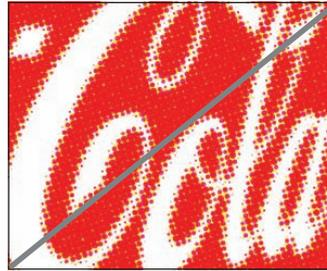

Do not use CMYK colors if spot color printing is available.

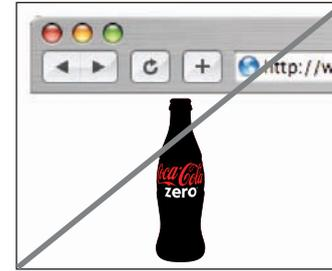

Do not use CMYK breakdowns in onscreen executions; use RGB or HEX breakdowns instead.

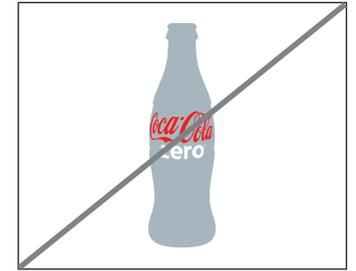

Do not ignore the color rules specific to each Element in the Brand Standards.



Do not use unapproved colors for the The Coca-Cola Zero Logo.



Do not add gradients or multiple tones of color to the Brand colors.

Typography

The Brand Standards use the Gotham font family. This font family can be purchased at www.typography.com.

Where local character language sets prohibit its use, the local market Group should set and communicate a standard that is as close a representation to the Gotham typeface as possible.

Primary Font

- Gotham Bold should be used for headlines on all executions and Brand communications.

Body Copy

- Gotham Book should be used for body copy on all Brand communications.

Secondary Font

- Gotham Medium should be used for functional messages only, such as pricing or a call to action.

Substitute Font

- When Gotham is unavailable, the Arial font may be used as a replacement for internal communications or html text only. Arial should never be used in consumer executions.

Usage Rights

- The Coca-Cola Company does not have global rights to any of the Brand fonts.

Gotham Bold

ABCDEFGHIJKLMNOPQRSTUVWXYZ
abcdefghijklmnopqrstuvwxyz
0123456789

Gotham Book

ABCDEFGHIJKLMNOPQRSTUVWXYZ
abcdefghijklmnopqrstuvwxyz
0123456789

Gotham Medium

ABCDEFGHIJKLMNOPQRSTUVWXYZ
abcdefghijklmnopqrstuvwxyz
0123456789

ABCDEFGHIabcdefghi0123456789

Arial Bold

ABCDEFGHIabcdefghi0123456789

Arial Book

Headlines and Body Copy

Headlines

- Should always be set in lowercase type.
- Should never be set in all caps.
- Kerning -55.

Body Copy

- Should always be set with leading at +20% of the font size. For example, 10 pt. type with 12 pt. leading or 9 pt. type with 11 pt. leading (as shown right center).
- Should not be kerned more tightly or loosely than a "0" setting.
- Should always use sentence-capitalization rules.
- May align flush left, flush right or centered as appropriate.

Pricing and Call-to-Action Copy

- May vary in point size to create impact.
- Call-to-action copy should always be set in all lowercase.
- Currency symbols should be reduced to 60% of the total height of the numbers.
- Use Gotham Medium for the offer and sub-head.
- Use Gotham Bold for the price.

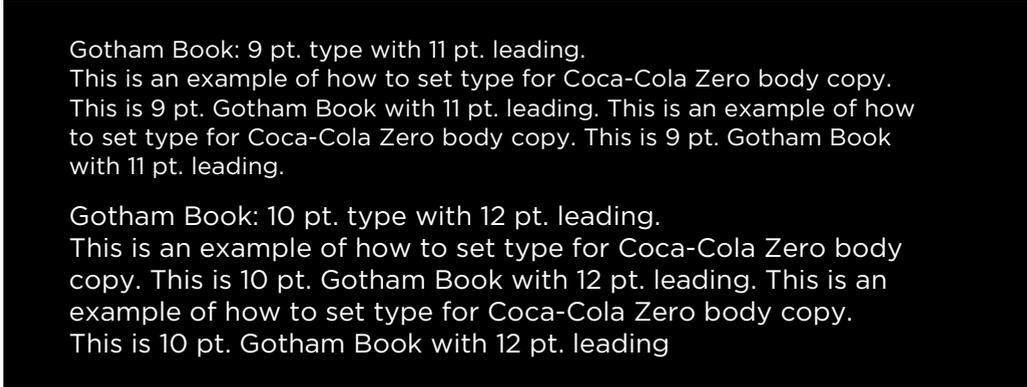

Backgrounds: Flat Colors

Use the backgrounds shown at right to emphasize a communication as well as the elements within it. Follow the standards below to ensure consistency for the Brand within a functional, flexible range of applications.

Black Background Color

Black is the primary background color.

- Use it in a simple and bold way to make an immediate and familiar connection with the consumer and leverage our 'ownership' of black.



Black background

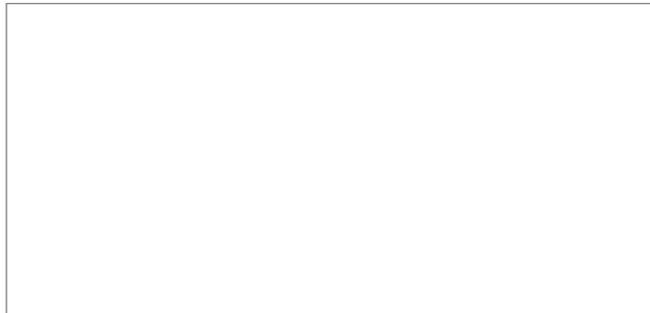

White background

Product Photography Art Direction

Coca-Cola Zero is nearly impossible to describe.
The product drives immediate craving for the liquid.

Coca-Cola Zero product photography should drive a desire for the uniqueness of the ice cold liquid, the smooth familiarity of the Contour Bottle, the multi-sensorial drinking experience and the refreshing uplift Coca-Cola Zero provides – physically and emotionally.

Photography of the product should elicit the following types of reactions from consumers:

- Cold and fizzy
- Sensual and soft
- Prickly and sharp
- Refreshing
- Surprising
- Relaxing
- Disposition-brightening
- Unlike anything on the planet



Contour Glass Bottle Photography

Gold Standard Contour Glass Bottle Photo

The Contour Bottle photo is a primary trademark for the Coca-Cola Zero Brand and the standard by which all future photography should be measured.

Use this Bottle photo for all product hero photography. However, if other Bottle perspectives or angles are needed, use this photo and the art direction outlined below as a photography guide for Bottle shape, graphics, lighting, condensation, ice, product color and glass color.

Approach

- Always present the product as hero.
- Make sure each product shot conveys a feeling of ice-cold refreshment and uplift – capturing that “PSHTTTTTT” moment when the Bottle is uncapped.
- Remember that the product adds iconic value.
- Remember that the product shot makes a visual invitation to consumers to purchase and consume the product.

Bottle Graphics

- Bottle mock-ups should be developed for all photography of the Bottle in order to maximize the size and impact of the Coca-Cola Zero Logo.

Bottle Shape and Color

- The North America 8 oz. Bottle is used for the Global Standard Contour Bottle photo and is the best representation of the Contour Bottle shape, color and formation of flutes.
- This Bottle should be used for all hero product photography and can be obtained from a North America Bottle supplier.

Style

- Clean, simple and bold.
- Devoid of extraneous elements.

Angle

- Products should be photographed front-on at eye level with very little perspective so that the bottoms of the products are flat and can be aligned next to each other as a range.
- While a straight-on approach is preferred, alternate perspectives are permitted in special cases where straight-on doesn't match the perspective needed.

Product Color

- Coca-Cola Zero product should have an overall cola color, but should include areas of highlight (sunset oranges and yellows) and darkness (dark chocolate) with hints of caramel and deep red tones.
- The right product color for photography can be achieved with a mix of product and water.
- The liquid must not be opaque nor a single color or shade.
- When the cap is off, be sure to capture the uplifting bubbles to indicate the 'pshttttt' of a freshly-opened bottle.
- Always reference the Gold Standard Contour Bottle photo for the ideal expression of the Coca-Cola Zero product.

Lighting

- The various product tones can be achieved by placing a chrome reflective card directly behind the product and using 2 soft boxes for the front lighting and a soft light for back lighting.

Refreshment Cues

- Condensation and ice can be used to add refreshment, but should be used sparingly and have the right balance.



Photography Details



Condensation



Uplifting Product Bubbles

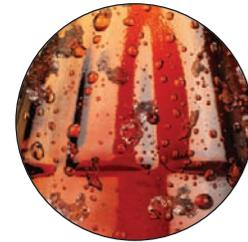

Correct Balance of Condensation



Maximize Script Size



Maintain Darks and Highlights

Cans, PETs, Other Packaging

Style

- As with the Contour Bottle, make the photograph clean, simple and bold.
- Keep the shot devoid of extraneous elements.
- Use reflections at your discretion. Consider what best suits each application.

Angles

- Angle should be straight-on at eye level with very little perspective. This allows the bottoms of the products to be flat and aligned next to each other as a range.
- In special cases where a straight-on approach doesn't match the perspective, alternate perspectives are permitted.
- A more heroic product angle can be used when it better suits a given execution (e.g., can photos on a fridge pack).

Product Color

- Coca-Cola Zero product should have an overall cola color, but should include areas of highlight (sunset oranges and yellows) and darkness (dark chocolate) with hints of caramel and deep red tones.
- The liquid must not be opaque nor a single color or shade.
- When the cap is off, be sure to capture the uplifting bubbles to indicate the 'pshtttt' of a freshly-opened Bottle.
- Reference the Gold Standard Contour Glass Bottle photo for the ideal expression of the Coca-Cola Zero product.

Refreshment Cues

- Condensation and ice can be used to add refreshment, but should be used sparingly and have the right balance.
- When photographing cans and PETs together, make sure that the refreshment cues are placed randomly and vary in size and shape (instead of covering the entire product) for each product shown.
- Packaging photos placed within other packaging (i.e., the can photo on the fridge pack) should be photographed with condensation to counterbalance the more iconic Elements of the overall design.



Package Design Standards

3.0

Contents

Packaging: Graphic Design Standards.....	3.02	Packaging: Form Design Standards	3.24
Overview	3.03	The Standard Contour Bottle Form	3.25
Package Framework.....	3.04	Industrial Design Principles for Packaging Form.....	3.26
Package Archetype		Elements of the Contour Bottle	3.27
Package Archetype: Sustaining.....	3.05	Understanding the Contour Bottle.....	3.28
Package Archetype: Thematic	3.06	Contour Bottle Elements: Applied.....	3.29
Essentials of the Coca-Cola Zero Label.....	3.07	Defining Elements	3.30
Printing Black		Achieving the Contour Bottle	3.31
Printing Black on Labels.....	3.08	Glass: Do's	3.32
Printing Black on Paperboard.....	3.09	Glass: Don'ts.....	3.33
Printing Black on Clear Shrink Wrap.....	3.10	Glass: Scaling.....	3.34
Printing Black on Glass Bottles	3.11	PET: Do's	3.35
Black Closures.....	3.12	PET: Don'ts.....	3.36
Color Measurement, Evaluation and Calibration		PET: Do's and Don'ts	3.37
Measuring Color Temperature.....	3.13	PET: Scaling	3.38 - 3.39
Visual Color Evaluation	3.14	Aluminum: Do's	3.40
Numeric Color Measurement.....	3.15	Aluminum: Don'ts.....	3.41
Calibration and Certification	3.16	Aluminum: Scaling	3.42
Sustaining Coca-Cola Zero Packaging Templates.....	3.17	Contour Bottle Construction.....	3.43
12 oz. Can	3.18	Overall Proportion: Schematic	3.44
500ML PET	3.19	Overall Proportion: Do's and Don'ts.....	3.45
2L PET.....	3.20	Contoured Shoulder: Do's and Don'ts	3.46
8 oz. Aluminum Bottle, ACL Bottles: 1-Color and 2-Color.....	3.21	Flutes: Do's and Don'ts (location).....	3.47
12 oz. Can Fridge Pack	3.22	Flutes: Do's and Don'ts (frequency)	3.48
Paper Cup	3.23	Flutes: Do's and Don'ts (section).....	3.49
		Pinch Waist: Do's and Don'ts (format).....	3.50
		Executional Constraints for Glass, PET and Aluminum.....	3.51
		Material and Process Considerations	3.52 - 3.53
		Overview of Executional Constraints	3.54

Packaging: Graphic Design Standards

The Brand Identity and Design Standards support a unified Trademark strategy for Coca-Cola, Diet Coke/Coca-Cola light and Coca-Cola Zero. It is based on the use of iconic Brand Elements, central to which are the Coca-Cola Zero Logo, the Contour Bottle, the Dynamic Ribbon and solid background colors.

The following pages provide guidance on using these Elements to consistently execute the strategy in your market.

Overview

The Coca-Cola Trademark Packaging System is fundamental to achieving a timeless, bold, simple and unified expression of brand identity and meaning. Through its proper application across Coca-Cola, Diet Coke/Coca-Cola light and Coca-Cola Zero, we increase differentiation, shelf impact, Brand consistency, scale and cultural relevance – all vital to a strong leadership position.

An iconic design approach to the Coca-Cola Zero Logo and the Dynamic Ribbon – two of the Brand's most recognized trademarks – forms the visual core of the Coca-Cola Zero Packaging System. In the pages that follow, these key Brand Elements find authentic expression through a strategic framework of bold simplicity and owning black.

All the design elements needed to create successful packaging executions for Coca-Cola Zero are shown in this System.

Approved digital files of customizable graphics and design templates for Packaging are available on the Design Machine website at www.coca-coladesignmachine.com. Please use only the approved versions supplied there.



Package Framework

The strategic framework for the Coca-Cola Zero Packaging System provides a unified approach for:

- Sustaining (i.e., permanent) executions
- Campaign (temporary) executions
- Properties (temporary) executions

Uniting them all is a design structure that ensures the consistency needed to leverage Brand equity while offering situational flexibility.

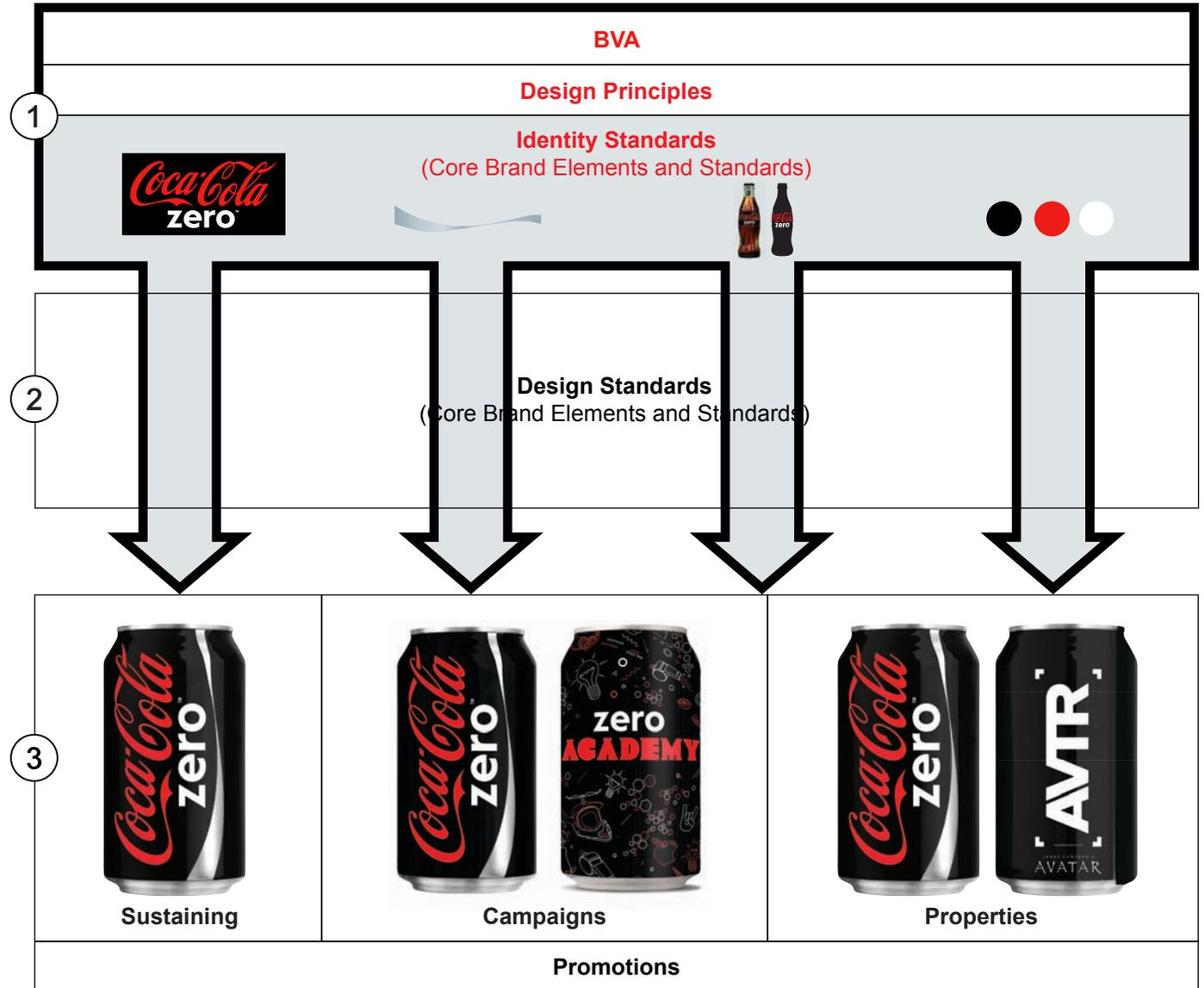

Package Archetype: Sustaining

Panel order may change by market; revise order as needed.

Front Panel: Fixed

- The Coca-Cola Zero Logo must always be present and appear as shown at right.
- The Dynamic Ribbon* must be present on all labels except ACL glass bottles where space permits.
- The Dynamic Ribbon is optional on the aluminum Contour Bottle.
- Do not move, resize or alter the Coca-Cola Zero Logo or Ribbon.
- Do not change their placement relative to one another.
- Do not replace them with other elements.

Middle Panel: Fixed

- The Coca-Cola Zero Logo and the Dynamic Ribbon must always be present and appear as shown.
- Do not move, resize or alter them.
- Do not change their placement relative to one another.
- Do not replace them with other elements.
- An International Variant of the Coca-Cola Zero Logo may be used on this panel only.

Back Panel: Fixed

Always include these elements:

- Secondary Logo
- Nutritional information
- Product barcode
- Recycle symbol

*While typically known as the Dynamic Ribbon, the legal trademark name is Dynamic Ribbon Device. Consult with your local legal counsel for usage guidance.

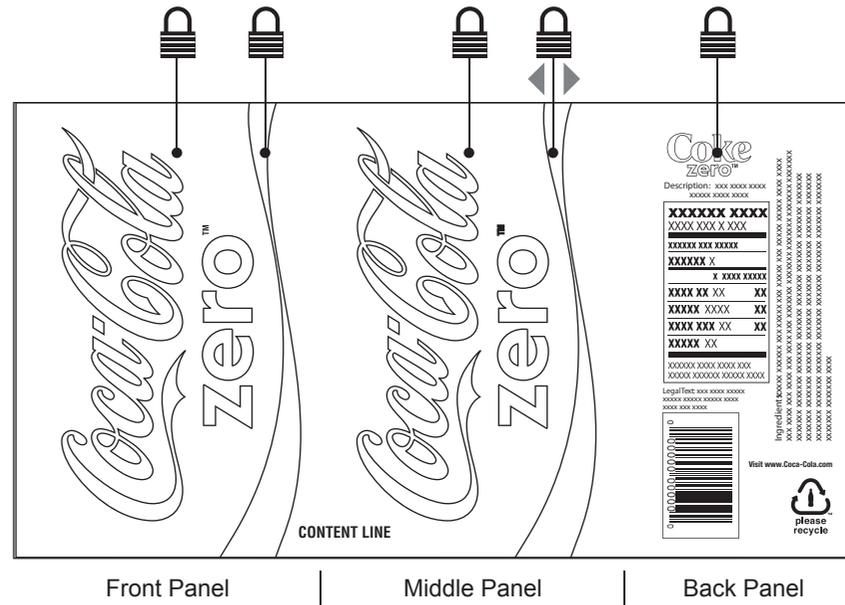

Package Archetype: Thematic

Panel order may change by market; revise order as needed.

Front Panel: Fixed

- The Coca-Cola Zero Logo must always be present and appear as shown at right.
- The Dynamic Ribbon* must be present on all labels except ACL where vertical space is limited.
- The Dynamic Ribbon is optional on the aluminum Contour Bottle.
- Do not move, resize or alter the Coca-Cola Zero Logo and Ribbon or their placement relative to one another.
- Do not overlap more than 5% of the Coca-Cola Zero Logo or the Ribbon with a thematic design.

Middle Panel: Flexible

- The Dynamic Ribbon must appear, but may be slightly shifted to the right or left.
- The Coca-Cola Zero Logo is an optional design element and may be replaced by thematic designs on this panel only.
- Do not overlap more than 5% of the Coca-Cola Zero Logo or the Dynamic Ribbon with a thematic design.

Back Panel: Fixed

Always include these elements:

- Coca-Cola Zero Logo
- Nutritional information
- Recycle symbol
- Product barcode

* While typically known as the Dynamic Ribbon, the legal trademark name is Dynamic Ribbon Device. Consult with your local legal counsel for usage guidance.

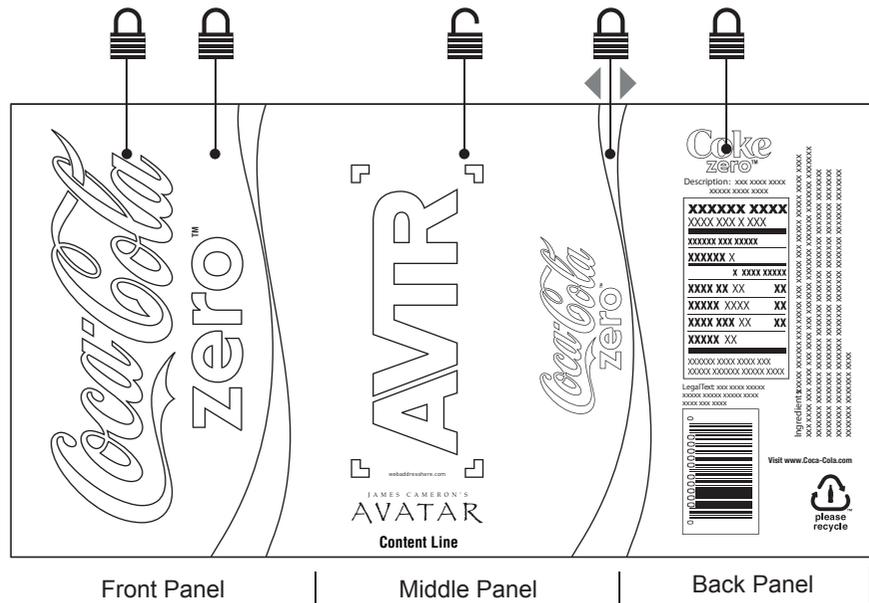

Essentials of the Coca-Cola Zero Label

The Coca-Cola Zero label is a unique amalgam of six Brand Elements.

- Every package label must include all six Brand Elements, in accordance with the guidelines shown in these pages.
- Elements must not be replaced, altered or resized relative to one another. Refer to the illustration provided as a general template.
- Learn more about these fundamental Brand Elements in the Core Brand Elements and Standards chapter (2.0).

Coca-Cola Zero Logo

The Coca-Cola Zero Logo is the cornerstone design element of the Trademark Packaging System. Being 'utterly familiar' with the Coca-Cola Zero Logo allows us be continually surprising with other elements. The Script must:

- Always be present and the most predominant Element.
- Always be used in its original form as shown in this System, without any drop shadows, outlines or alterations of any kind.
- Always be scaled to fill the space in which it is placed, as shown in the illustration.
- Always be shown as Coke Red and white on a black background.
- Never be used in other colors, whether or not they are in the Brand color palette.

Dynamic Ribbon

The Dynamic Ribbon is used to support the Brand colors and to help communicate the various flavors.

- It must always be present and be used in its original form as shown in this System, without any drop shadows, outlines or alterations of any kind.
- The Lock-up for the Dynamic Ribbon and the Coca-Cola Zero Logo is fixed and must not be changed.
 - The Coca-Cola Zero Logo must be centered over the middle of the Dynamic Ribbon. For detailed guidance on the correct Lock-up of the Coca-Cola Zero Logo and Dynamic Ribbon, please refer to the Lock-up Specifications page in the Dynamic Ribbon section of the Core Brand Elements and Standards chapter (2.0).
 - The two must never overlap.

Coke Zero Logo

- The Coke Zero Logo must always appear on the back panel of the packaging alongside the nutritional statement.
- It must always be shown as Coke Red and white on a black background.
- It must never be shown in other colors, whether or not they are in the Brand color palette.

Contour Bottle (Optional Panel Graphic)

Signifying Coca-Cola Zero at a glance, the Contour Bottle must:

- Always be shown as Coke Red and white on a black background.
- Never be shown in other colors, whether or not they are in the Brand color palette.
- Remain the same shape, although its content and expression may vary across executions.

Typography

- Helvetica Bold Condensed is the primary typeface for packaging.
- It must always be used to communicate content size, nutritional information and ingredients.

Helvetica Bold Condensed

ABCDEFGHIJKLMNOPQRSTUVWXYZ

abcdefghijklmnopqrstuvwxyz

0123456789

Black

Black must be the predominant color on the Coca-Cola Zero label, thus consistently leveraging the Power of Black.

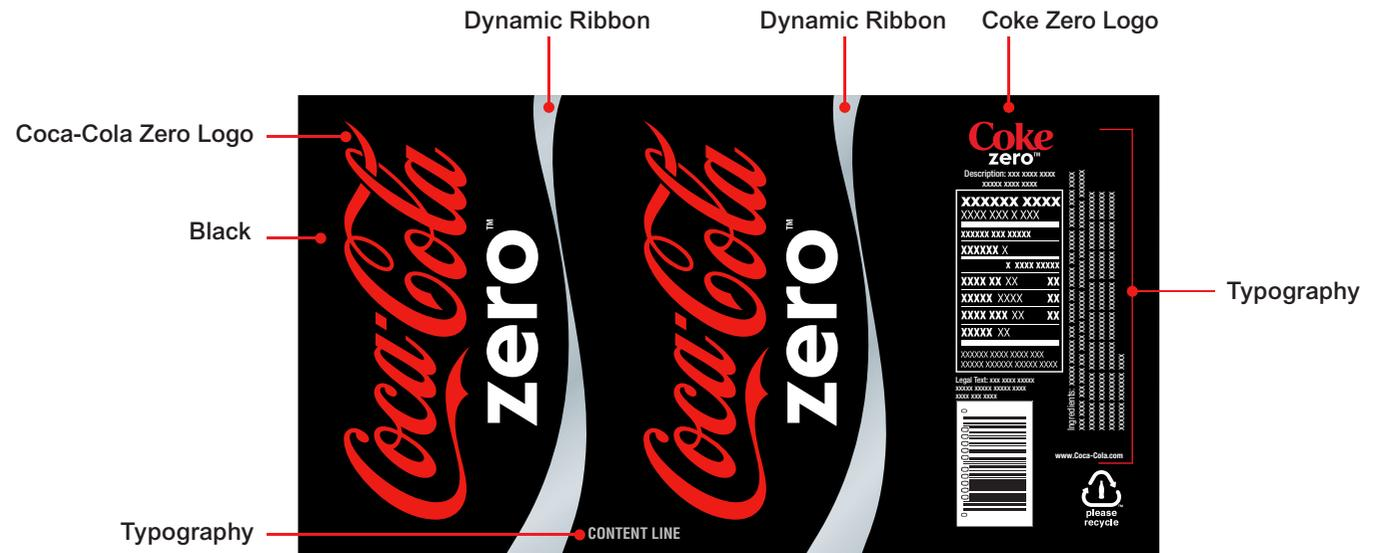

Printing Black on Labels

To ensure bold, impactful labels on label substrates, follow the guidelines and ink measurements outlined in the print specifications below.

Always bleed the black ink to the edge in order to prevent white edges.

Polypropylene Substrate

A single color of black should be reverse-printed on clear substrate and laminated to white substrate.

Plastic Substrate

A single color of black should be surface-printed on white substrate and overprinted with clear varnish.

Paper Substrate

A single color of black should be surface-printed on white substrate and either overprinted with clear varnish or laminated.

Printed black Ink Standards

Visually match to the black Global Color Standard.

For more guidance please refer to:

- The Color Measurement, Evaluation and Calibration pages later in this section; and
- The Specular Reflectance Curve information in the Color Palette section of the Core Brand Elements and Standards chapter (2.0).

For a visual color match on polypropylene substrate, please contact the Global Design Group.



Printing Coke Red and Black & White on Paperboard

To ensure bold, impactful multi-packs on paperboard substrates, follow the guidelines and ink measurements outlined in the print specifications below.

Paperboard Substrate

Print black ink to achieve the proper silver reflectance.

Printed Coke Silver Ink Standards

Match to the black Global Color Standard visually.

For more guidance please refer to:

- The Color Measurement, Evaluation and Calibration pages later in this section; and
- The Specular Reflectance Curve information in the Color Palette section of the Core Brand Elements and Standards chapter (2.0).

For a visual color match on paperboard substrate, please contact the Global Design Group.



Printing Black on Clear Shrink Wrap

To ensure bold, impactful multi-packs on clear shrink wrap substrates, follow the guidelines and ink measurements outlined in the print specifications below.

Shrink Wrap Substrate

Print a single lay down of white prior to a double bump of black ink to achieve the proper color intensity.

Printed Black Ink Standards

Match to the black Global Color Standard visually for HTL and ACL.

For more guidance please refer to:

- The Color Measurement, Evaluation and Calibration pages later in this section; and
- The Specular Reflectance Curve information in the Color Palette section of the Core Brand Elements and Standards chapter (2.0).



Printing Black on Glass Bottles

To ensure bold, impactful labels on glass Contour Bottles, follow the guidelines and ink measurements outlined in the print specifications below.

HTL Substrate

A single color of black should be reverse-printed on white substrate and heat transferred to a glass Bottle.

ACL Substrate

A single color of black should be surface-printed directly on a glass Bottle.

Printed Black Ink Standards

Match to the black Global Color Standard visually for HTL and ACL.

For more guidance please refer to:

- The Color Measurement, Evaluation and Calibration pages later in this section; and
- The Specular Reflectance Curve information in the Color Palette section of the Core Brand Elements and Standards chapter (2.0).



Black Closures

Always utilize black color plastic substrate for closures on all Brand Coca-Cola Zero packs that require resealable caps.

Two-color closure printing is the preferred standard. If two-color closure printing is not an option, using white only is acceptable.



Visual Color Evaluation

Visual Color Measurement

The visual evaluation of color is subjective. By standardizing the viewing environment and procedures, the consistency of our trademarks improve.

The primary objective of The Coca-Cola Color Management System is for all facets of our Company's trademarks to be a direct reflection of the quality of our Brands. First and foremost, any reproduction of our Company Brands must visually match approved Visual Color Standards issued.

The Color Standards represent the Final Product Appearance. Any adjustments needed to compensate for the effects of coatings, additives, varnishes and/or traps, etc. to the final appearance must be taken into consideration by printers.

Visual Color Evaluation

The intent of this practice is to standardize the procedures for the visual evaluation of printed samples. These procedures are to be used when visually comparing a printed sample against the approved Color Standard.

Proper viewing conditions, normal color vision and correct positioning of the standards and samples are essential to maintaining a standardized visual evaluation process. Once the visual evaluation has taken place, the results must then be confirmed through the use of instrumentation when applicable.

Equipment

Proper lighting or viewing environments (such as GTI ColorMatcher or MM-1) are essential for consistent visual evaluation. See the "Simulated Lighting Conditions" chart on the next page for desired light sources.

Lighting

The area where color evaluations are conducted must have a booth or enclosed area with a standardized overhead lighting system. The lighting system must be capable of providing the simulated lighting conditions described on the following pages.

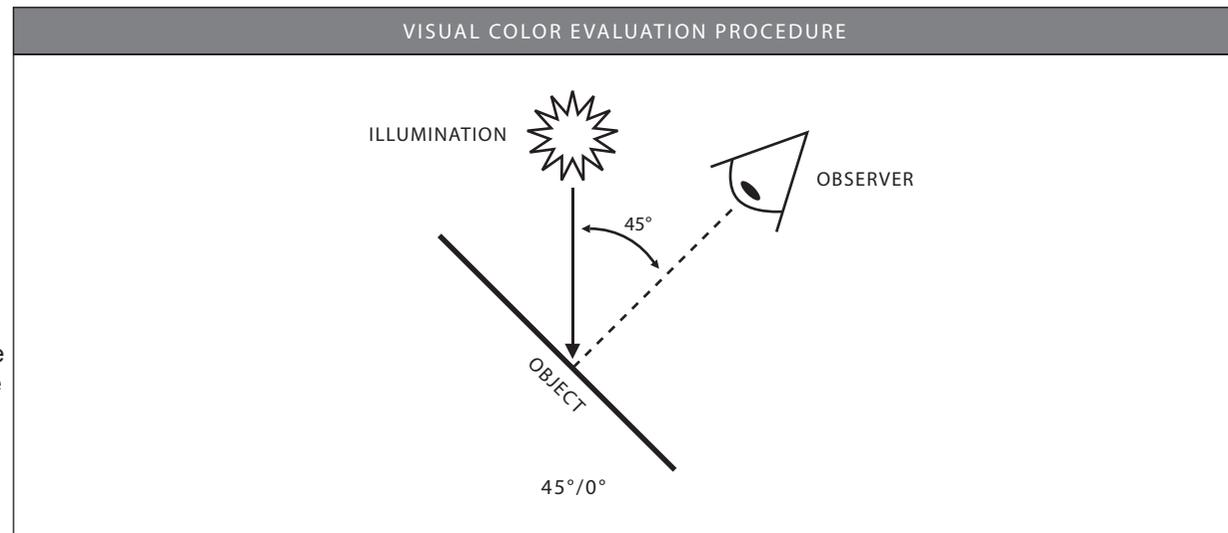

Measuring Color Temperature

Color Temperature Measuring Instruments

A properly calibrated, traceable spectroradiometer can be used to check the color temperature and relevant parameters of each source.

Viewing Environment

The ambient lighting conditions must not interfere with the controlled lighting from booths or viewing environment.

Gray surround color (Munsell N/7) and curtains, if necessary, are to be used. An enclosed viewing room painted with gray (Munsell N/7) paint is acceptable in lieu of a lighting booth.

Observers should wear neutracolored clothing or smocks so as not to influence the reflected color back to the sample being evaluated.

When samples are being viewed, there should be no other items present in the booth or area other than the sample and standard being evaluated.

If light is being reflected off walls in close proximity to the evaluation area, there should not be any distracting or brightly colored objects nearby.

Simulated Enclosure Size

The size of the booth, room, etc. should allow for comfortable viewing. There should be enough space to view all areas from different angles and still remain in the controlled lighting environment.

Lighting System Maintenance

Proper maintenance in accordance with the manufacturer's recommendations of the lighting equipment is essential for consistency over time and between units. Lamps are to be replaced when the unit is out of specification for intensity or color temperature. Replace lamps only with those obtained from the original manufacturer of the product in accordance with the manufacturer's recommended replacement schedule.

SIMULATED LIGHTING CONDITIONS	
PRIMARY LIGHT SOURCE	Daylight with color temperature of 5000°K.
SECONDARY LIGHT SOURCE	Cool White Fluorescent (CWF) source with a color temperature of 4000°K.
TERTIARY LIGHT SOURCE	Optional: This light source should be selected and standardized by each Company Division office if needed. The use of a tertiary light source other than Cool White Fluorescent is the primary store lighting condition in the Division's geographic area. If the local store lighting conditions are primarily Cool White Fluorescent, Incandescent (2856°K) can be used as the tertiary light source.
ULTRAVIOLET LIGHT SOURCE	Optional: This is normally used to evaluate optical brighteners, whitening agents, fluorescent pigments and dyes.
(Note: All of the above is covered in detail in ASTM D1729-96.)	

Numeric Color Measurement

Color communicates. Because the colors of our trademarks are such an integral element of the Brands' identity, it is critical that our Brand colors be reproduced with uncompromising quality and consistency.

In addition to the Visual Color Standards, the Color Standards are provided electronically in the form of a .MIF file. The .MIF file will be sent via email. This Digital Color Standard should be downloaded directly into your X-Rite QA Master software. Downloading the Digital Standards directly into the software ensures that everyone evaluating our Brand colors will be using the exact same numeric values for consistency.

This Digital Color Standard contains:

- Absolute L*a*b* Values
- Standardized Illuminants
- Standardized Observer
- Digital Tolerances
- Reflectance Values

Digital Tolerances

Standards using the specified X-Rite equipment and QA Master software incorporate the specifications shown.

General Methods for Measurement

Instruments must be calibrated with the assigned tile and within the manufacturer's tolerance. The sample size must be at least 4 mm and large enough for the measurement window of the instrument to be covered completely. It is also very important to ensure that there are no physical defects in the area (color) being measured. An average of 3 readings may be taken to ensure a representative reading of the sample.

INSTRUMENTAL COLOR MANAGEMENT SPECIFICATIONS			
INSTRUMENT	X-Rite® 939 or 530		
MEASUREMENT GEOMETRY	0/45		
APERTURE	No smaller than 3.4 mm		
SOFTWARE	X-Rite QA Master® or QA Master 2000®		
FILE TRANSFER FORMAT	.MIF		
STANDARD OBSERVER	10 Degree		
PRIMARY ILLUMINANT	Daylight D50/10	5000°K	
SECONDARY ILLUMINANT	Cool White Fluorescent (F2)	4000°K	Coke Red Only
TERTIARY ILLUMINANT	Optional: This light source should be selected and standardized by each Company Division office if needed. The use of a tertiary light source other than Cool White Fluorescent is the primary store lighting condition in the Division's geographic area. If the local store lighting conditions are primarily Cool White Fluorescent, Incandescent (2856°K) can be used as the tertiary light source.		
COLOR SPACE	CIELAB		
COLOR TOLERANCE	CMC 2:1 (Numeric tolerances are specific to the individual color and substrate being measured.)		

Calibration and Certification

Calibration and Certification of the X-Rite 939 or 530

It is extremely critical that all individuals who are responsible for using the X-Rite 939 or 530 conduct the calibration process correctly and consistently. To ensure accuracy, the X-Rite 939 or 530 has safeguards to maintain proper calibration. The first safeguard is an internal clock that will prompt the user to re-calibrate every 12 hours. As a second safeguard, the instrument will prompt re-calibration if the temperature of the instrument chassis drifts 7° Fahrenheit. The instrument will always alert the user when it requires calibration. Even with these safeguards, however, it remains the obligation of the user to ensure that calibration is done correctly.

Please note: Calibration due to temperature change occurs at a 10° shift in temperature.

Equipment:

- X-Rite 939 or 530 Spectrophotometer
- CMC light source D50/10 degree
- Calibration tile with current expiration date
- X-Rite QA Master software with computer
- Numeric color library (MIF)

Instrument Settings

Before taking any readings with the X-Rite 939 or 530, ensure that the following functions are selected within the instrument:

- L*a*b* mode
- D50 illuminant
- 10° observer

Sustaining Coca-Cola Zero Packaging Templates

Use only the approved customizable graphic templates available on the Design Machine website.

Always follow the Fixed But Flexible approach to ensure consistent design while customizing packages as needed.

Caveats

- Ensure at all times that at least one strongly branded panel is present on the package.
- Do not print refreshment cues (condensation or ice) on packs.
- All package layouts must be submitted for local or regional approval through legal and Bottler reviews.
- All local legal registration notices must be applied to all trademarks.
- Back-of-package information must be applied in accordance with local requirements, including:
 - GDA (Guideline Daily Amounts).
 - “Romance” or promotional copy.
 - Secondary back-of-package Logos (as space permits).
- Guidance for printers must be supplied on all artwork files.



12 oz. Can

Coca-Cola Zero 12 oz. Can



Color Specs:

- Black
- Pure Silver
- Coke Red
- White



500ML PET

Coca-Cola Zero 500ML PET



bleed ink to edge
(no white borders)

Color Specs:

- Black
- Pure Silver
- Coke Red
- White Substrate



Bottle.

2L PET

Coca-Cola Zero 2L PET



bleed ink to edge
(no white borders)

- Color Specs:
- Black
 - Pure Silver
 - Coke Red
 - White



8 oz. Aluminum Bottle, ACL Bottles: 3-Color

Coca-Cola Zero 8 oz. Aluminum Bottle



Color Specs:

- Black
- Coke Red
- White
- Silver Substrate



ACL Bottle: 3-Color



Color Specs:

- Black
- Coke Red
- White



12 oz. Can Fridge Pack

Coca-Cola Zero 12 oz. Can Fridge Pack



Color Specs:

- Black
- Pure Silver
- Coke Red
- White



Paper Cup

- In cases where the Recycled PET Cup cannot be utilized, use a paper cup with this standard design.
- Do not alter the design or its elements in any way.

For more guidance on properly using Food Service Cups in your market, please contact the Global Packaging Group or North America Food Service Team.



Packaging: Form Design Standards

The Contour Bottle is the standard package for Coca-Cola Zero. Universally recognized, the Contour Bottle evokes the heritage of the Coca-Cola Zero Brand and expresses the uplifting experience of drinking a Coca-Cola Zero.

The Global Standard Contour Bottle is the archetype from which we derive the rules for packaging executions in all markets and across a range of materials and sizes.

The Standard Contour Bottle Form

In 1960, The Coca-Cola Company convinced the United States Patent and Trademark Office that the very shape of what we know now as the Contour Bottle had become so well known that it deserved the status of a registered trademark. Applying for a trademark for a commercial package was a most unusual and bold step at the time. But the Company wisely knew that whereas patents eventually run out, a trademark does not; so as long as it is kept in continuous use, a trademark lasts indefinitely.

The Company presented the case that the very shape – in their words, the “distinctively shaped contour” of the “hobble skirt bottle” – was “the most recognized container in the history of the world” and had in effect already taken on trademark status. The USPTO agreed and granted a registered trademark to Coca-Cola for the Contour Bottle.

This chapter describes the Coca-Cola Zero Contour Bottle form standard and outlines how to execute it across various materials and sizes, specifically:

- Structural features that set the packaging standard for the Brand.
- How to translate structural features across packaging formats and materials.
- Design guidelines, including Do’s and Don’ts.
- Size extensions and scaling.
- Mastering technological and manufacturing constraints.



The Standard Contour Bottle Form



Glass



PET



Aluminum

Industrial Design Principles for Packaging Form

These are the Design Principles behind the Contour Bottle and should be used whenever developing packaging for Coca-Cola Zero.

1. Bold Simplicity

- A return to clarity; removal of all extraneous noise and static around the Brand to find the bold, simple essence of Coca-Cola Zero.

2. Real Authenticity

- We leverage all that is real, original and honest about the Brand.
- Clearly linking back to our heritage gives us the license to try new things and keep evolving.

3. Own Black

- At every touchpoint, we will leverage the Power of Black and ensure its consistency around the World. We will integrate the thread of Red into everything we do.

4. Familiar Yet Surprising

- We do not follow category norms; instead, we lead them.
- We introduce new strategic elements to create variety and freshness across the Brand experience.

Elements of the Contour Bottle

The Contour Bottle – our archetype and inspiration for bringing all other packaging to life – is composed of distinctive elements.

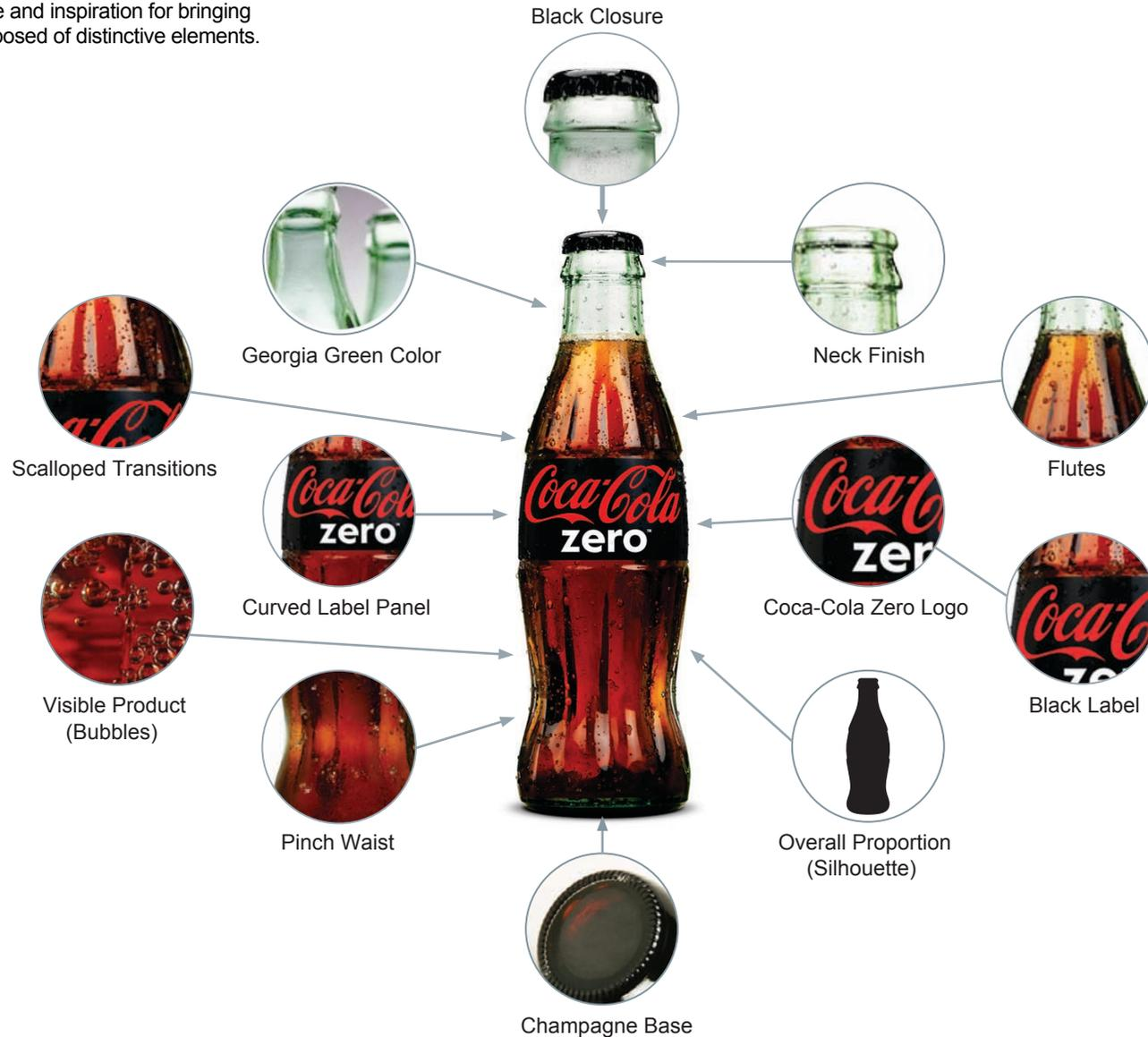

Understanding the Contour Bottle

The original project brief for the Contour Bottle that was given to the Root Glass Company of Terre Haute, Indiana, specified "... A glass package so distinctive as one containing Coca-Cola, so shaped that even if broken, a person could tell at a glance what it was, so distinguishable by touch that even a blind man could identify it."



Contour Bottle Elements: Applied

Defining Elements

The keys to creating our identity. Essential to packaging form.



Contoured Shoulder



Flutes



Scalloped Transitions

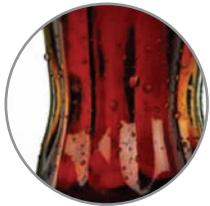

Pinch Waist



Champagne Base



Overall Proportions
(Silhouette)

(relationship of elements to each other, from base to pinch waist to label area to shoulder)



Supporting Elements

Ideal whenever feasible, but not essential.

True Form Elements



Black Closure

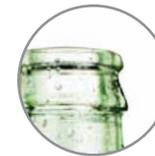

Neck Finish



Georgia Green Color



Curved Label Panel

Graphic Elements



Black Label



Color Palette

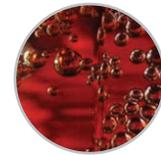

Visible Product
(Bubbles)

Defining Elements

Overall Proportion



The overall proportion is made up of **five basic sections** and **defines the iconic silhouette**: The Contoured Shoulder, Curved Label Area, Pinch Waist, Vertical Fluting and Overall Silhouette comprise the iconic proportion and have a **specific aspect ratio** to the overall package height.

Contoured Shoulder



The contour of the shoulder is symmetrical, slender and defined by **two elegant arcs** in a wave format. It starts the **flowing aesthetic** of the icon.

Flutes



Flutes are the **vertical ribs**. They **frame the Curved Label Panel** and create varying wall thicknesses in the bottle, **adding depth**. They also provide structure to a soft flowing form.

Pinch Waist

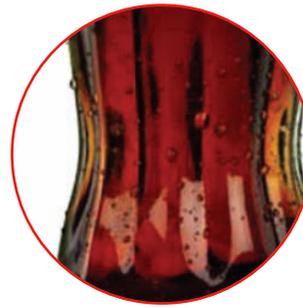

The Pinch Waist is located **below the label** and provides the most signature element of the Contour Bottle. It also creates a **slender, flowing aesthetic** that is the essence of the icon.

Scalloped Transitions



Created by the **resolution of the Flutes into the Curved Label Panel**, this distinctive detail **imparts a unique feel** when the Contour Bottle is held.

Champagne Base



Substantial and **symbolic of the integrity** of the product, the Champagne Base **emphasizes the Pinch Waist** and is where the Flutes terminate.

Achieving the Contour Bottle

Although technical and manufacturing constraints can prevent the perfect replication of the iconic Contour Bottle, the ideal execution for each material can be achieved by applying the Do's and Don'ts that follow.



Glass: Do's



Black Closure
Must use black closure.



Black Threaded Closure
May use a black threaded closure on a Contour Bottle.



Applied Color Label (ACL)
May use Applied Color Labels on glass Bottles.



Roll-fed Label
May use a roll-fed label or a split label.



Georgia Green
May use Georgia Green (dominant wavelength 515-545 nm) for glass Bottles.



Clear Glass
May use flint (clear) glass Bottle.

Glass: Don'ts



No Flutes

Flutes must always be present on glass Contour Bottles. They are a defining feature of the Contour Bottle and are technically feasible.



Straight Shoulder

The Contoured Shoulder must be present in all glass executions.



Straight Waist

The Pinch Waist is the most defining feature of the Contour Bottle and must always be present.

Glass: Scaling



Ideal

Scale proportionately while still using a common closure size.



Unacceptable

Don't vary diameters to maintain a common height.



Unacceptable

Don't vary heights to maintain a common diameter.

PET: Do's



Black Threaded Closure
Must use a black threaded closure on PET.



Short Height Closure
May use a black short height closure on PET.



Roll-fed Shrink Label
May use a roll-fed shrink label.



Roll-fed Label
May use a roll-fed label.



Petaloid Base
May use a petaloid base.



Clear PET
May use clear PET.



Georgia Green Color
May tint PET Georgia Green.



Recycled PET
Use highest RPET content feasible.

PET: Don'ts



No Flutes
Flutes must always be present on glass PET executions. They are a defining feature of the Contour Bottle and are technically feasible.



Replacing Flutes
Flutes must never be replaced with other shapes or textures.



Straight Waist
Do not eliminate the Pinch Waist.

PET: Do's and Don'ts



Colored PET

Pigmented PET (opaque or translucent) Bottles must not be used.



Champagne Base

Using a Champagne Base on a PET Bottle instead of the petaloid is permissible. Keep in mind, however, that it could add weight and cost while adversely affecting sustainable packaging outcomes.

PET: Scaling



PET: Scaling



Ideal

Scale proportionately while still using a common closure size.



Unacceptable

Do not vary diameters to maintain a common height.



Unacceptable

Do not vary heights to maintain a common diameter.

Aluminum: Do's



ROPP Closure
May use a black Rolled-on Pilfer-Proof (ROPP) closure on aluminum.



ROPP Closure
May use a black Rolled-on Pilfer-Proof (ROPP) closure on aluminum.



Contoured Shoulder
Maintain the iconic Contoured Shoulder.



Subtle Pinch Waist
Use a subtle pinch to mimic the Contour Bottle.



Champagne Base
Maintain champagne-style base.

Aluminum: Don'ts



Artificial Label Area
Do not create an artificial label area on the aluminum Contour Bottle.



Formed Flutes
Must forego Flutes on the aluminum Contour Bottle as it is not technically feasible to execute them properly.



Accent Flutes
Graphic Flutes are not authentic enough to replace true Flutes as the scalloped areas will be lost.



Straight Waist
The Pinch Waist is the most defining feature of the Contour Bottle and must always be present.



Straight Shoulder
The Contoured Shoulder must be present in all aluminum Contour Bottle executions.



Sacrifice Pinch Waist
Do not sacrifice the iconic quality of the Pinch Waist to add Flutes or a Curved Label Panel in the forming process.

Aluminum: Scaling



Scale proportionately while still using a common closure size.



Do not vary diameters to maintain a common height.



Do not vary heights to maintain a common diameter.

Contour Bottle Construction

This section includes critical technical details for the Defining Elements. It is essential that industrial designers and engineers use this documentation in order to properly integrate Defining Elements and to ensure the best possible Contour Bottle execution.

Please note: The Global Packaging Database must be consulted before creating a new Bottle design, as there are already many approved size and material iterations of the Contour Bottle in existence. The Global Packaging Database maintains up-to-date drawings for Ultra Glass Contour (non-returnable and returnable), PET (non-returnable and returnable) and Aluminum (non-returnable). Always choose the Bottle with the lowest gram weight. For access to the Global Packaging Database, please contact Darryl Dawson at 404.676.5582 or via email at ddawson@na.ko.com.

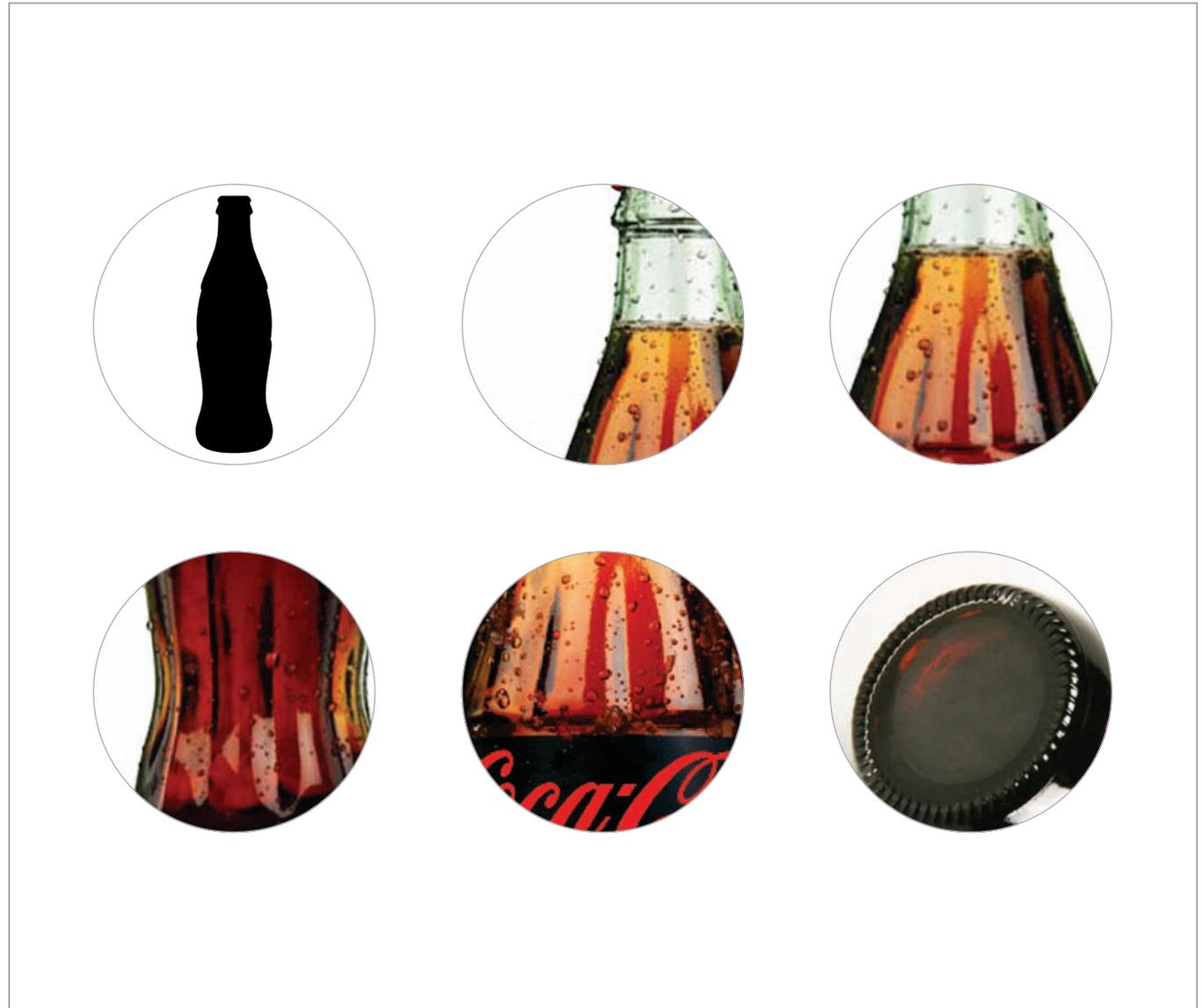

Overall Proportion: Schematic

The Ultra Glass Bottle proportions define the Contour Silhouette and its proportions. Dimensions shown here represent the 237 mL NR Ultra Glass Bottle. For other-sizes, refer to the percentages or see the addendum for specific Contour Bottle drawings.

1. Neck Finish
2. Contoured Shoulder
3. Curved Label Panel
4. Pinch Waist
5. Champagne Base

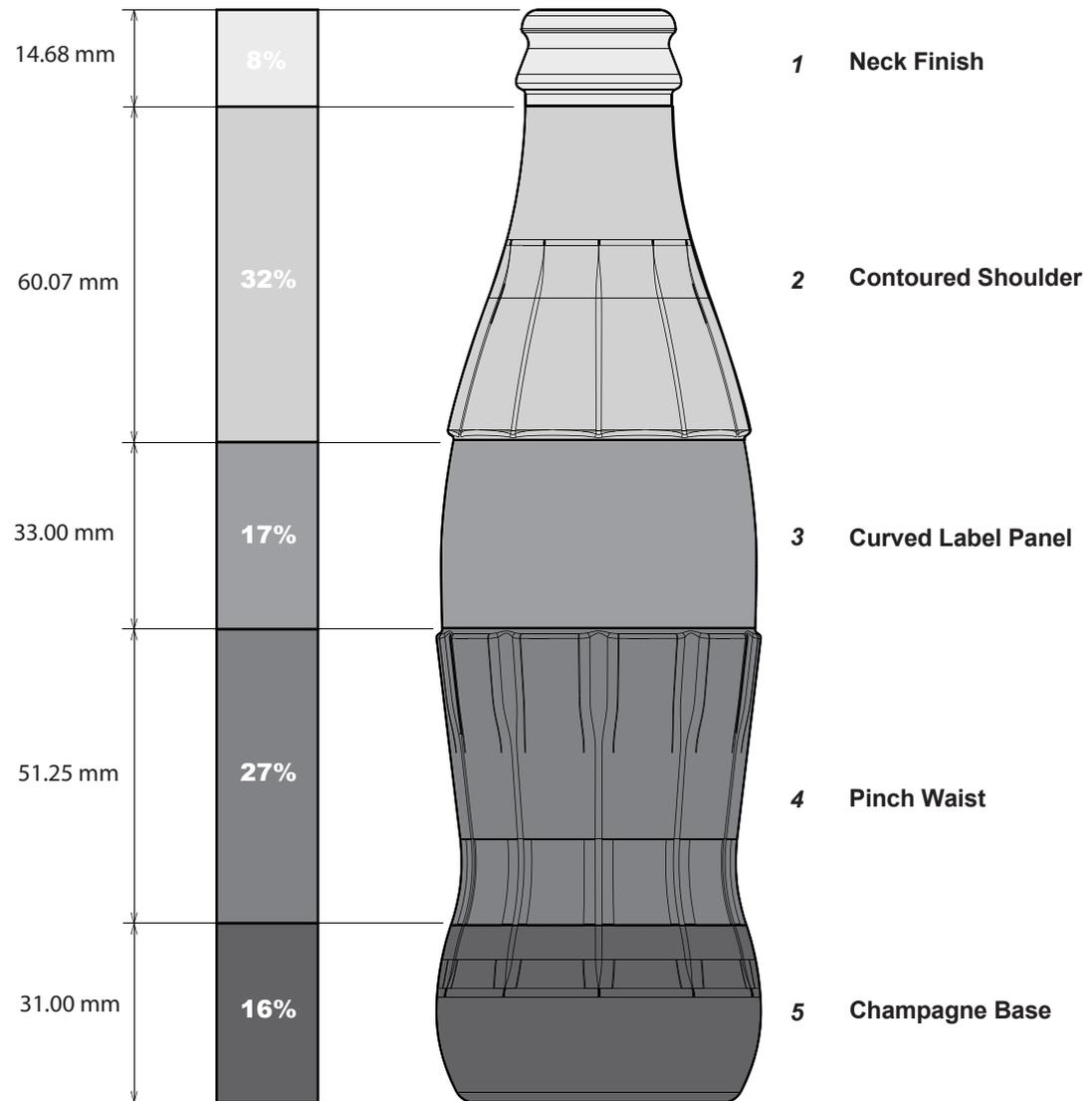

Overall height: 190 mm
Percentages = % of overall height

Overall Proportion: Do's and Don'ts

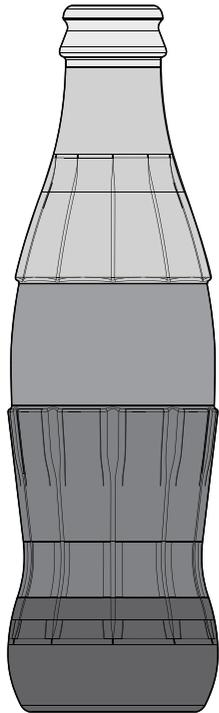

Correct

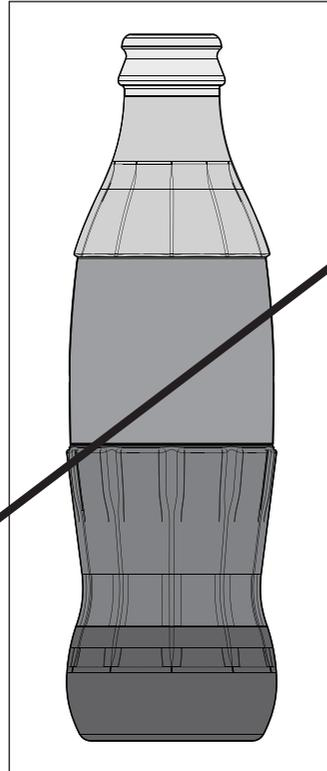

Increase Curved Label Panel
Do not increase the Curved Label Panel to add more graphics.

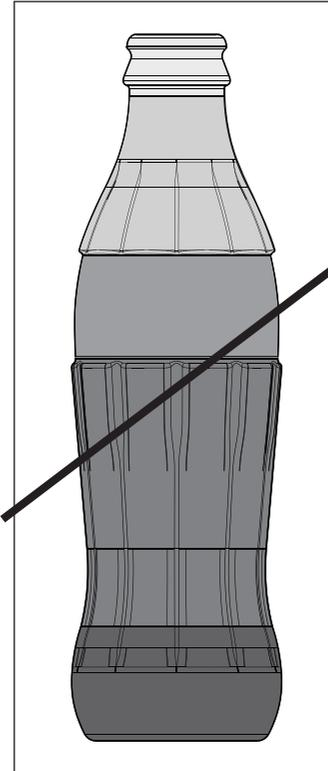

Increase Pinch Waist
Do not increase the Pinch Waist section to increase grip.

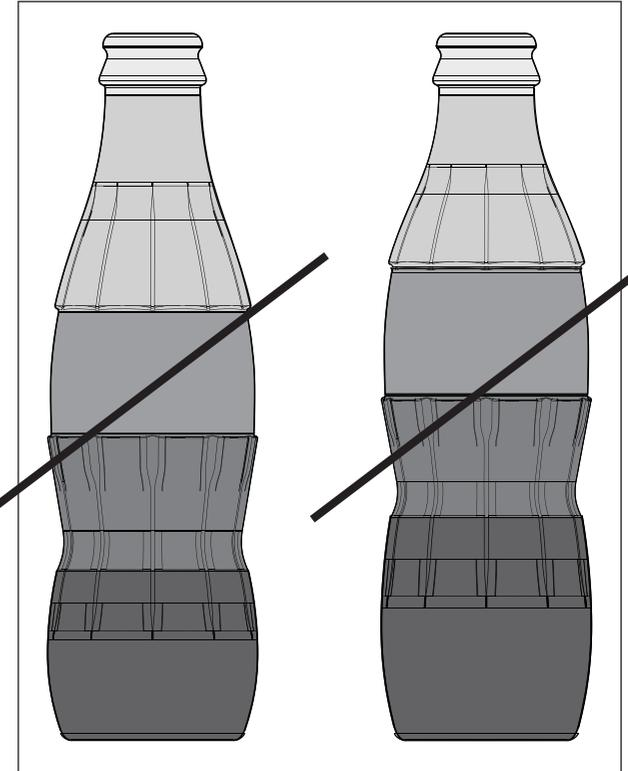

Change Pinch Waist Location
Do not change the location of the Pinch Waist within the overall proportions.

Contoured Shoulder: Do's and Don'ts

Correct

Double-arched Contour (sin-wave) defines the shoulder's contour in a symmetrical format.

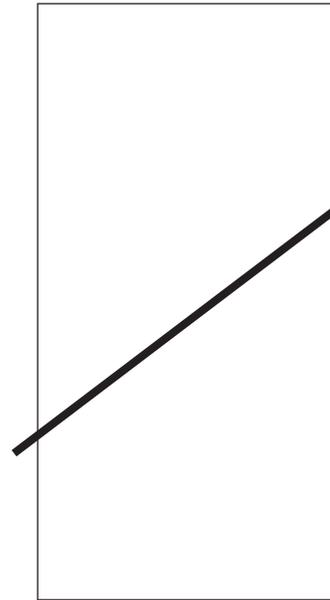

Straight

Do not use a straight shoulder.

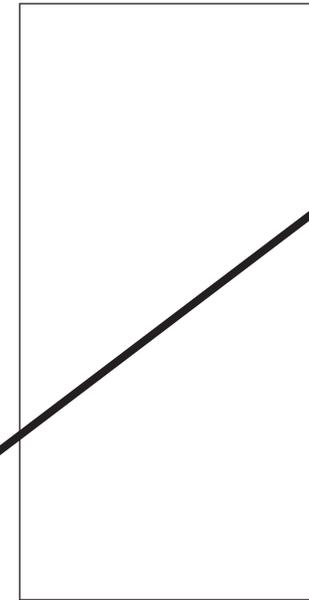

Single Curve

Do not use a shoulder comprised of a single curve.

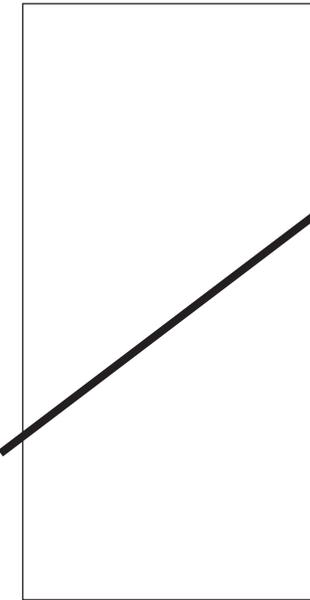

Bottle Neck

Do not introduce a true vertical to mimic a traditional bottle neck.

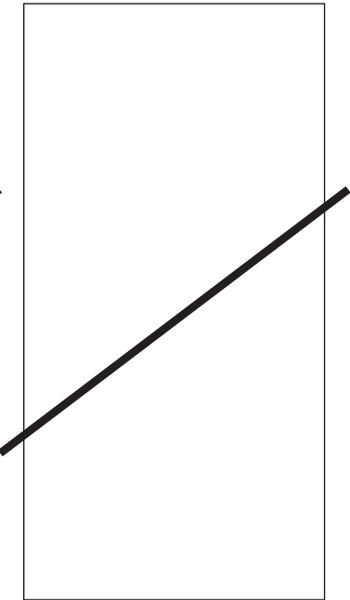

Asymmetrical

Do not use an asymmetrical transition with the Contour.

Flutes: Do's and Don'ts (location)

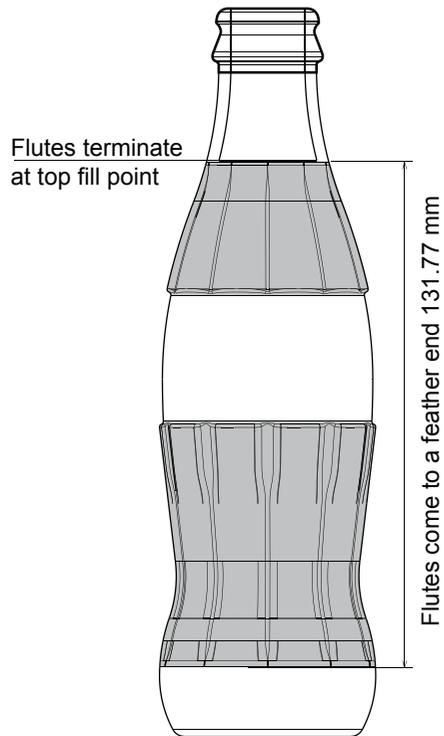

Correct
 Flutes must always be above and below the Curved Label Panel and span 131.77 mm on 237 mL Bottles.

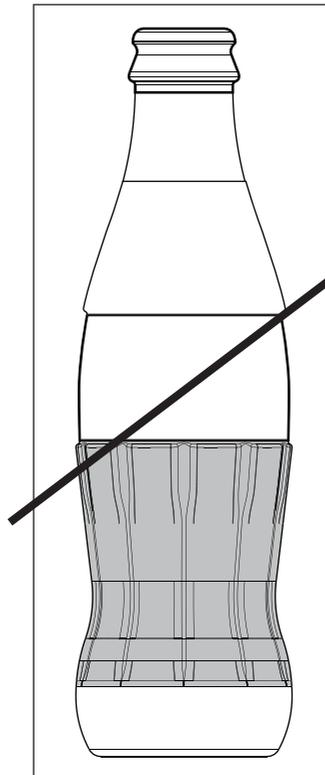

Bottom Only
 Do not use Flutes solely in the Pinch Waist area.

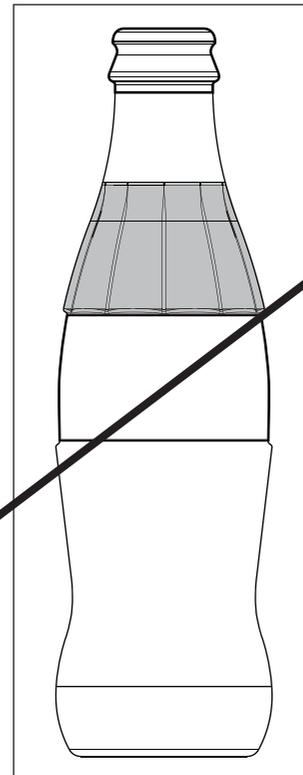

Top Only
 Do not use Flutes solely on the Contoured Shoulder.

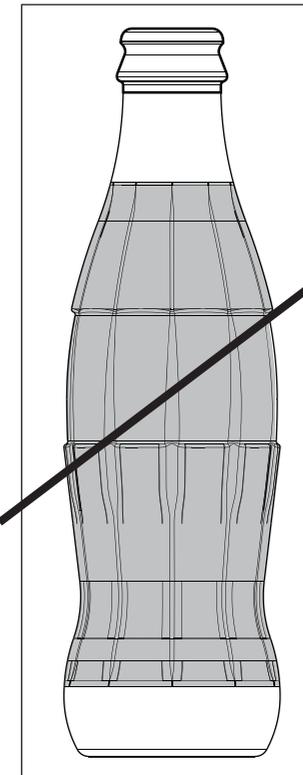

Continuous
 Do not continue Flutes through the Curved Label Area.

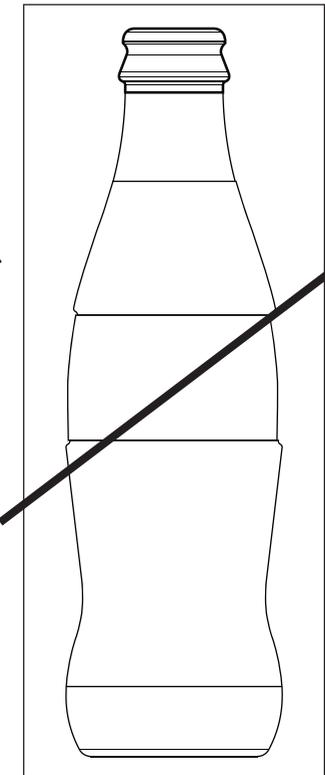

None
 Do not eliminate Flutes.

Flutes: Do's and Don'ts (frequency)

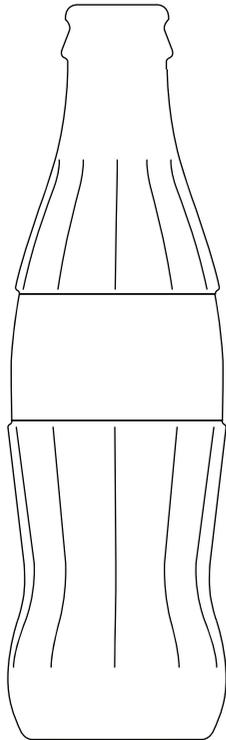

Correct
The Contour Bottle has 10 Flutes.

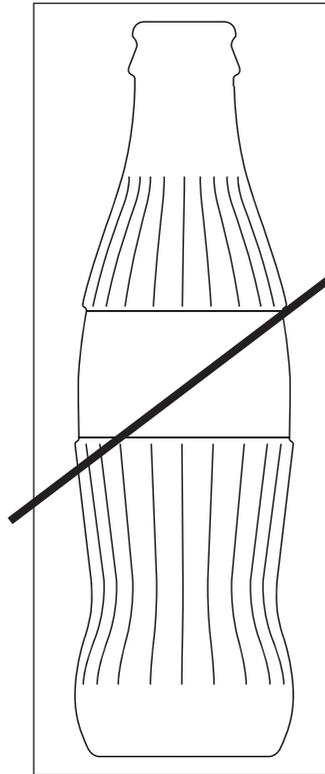

More than 10 Flutes
More than 10 occurrences is too frequent.

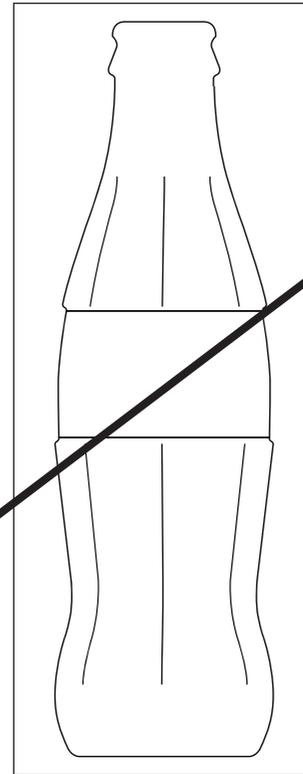

Less than 10 Flutes
Less than 10 creates an unwanted faceted look.

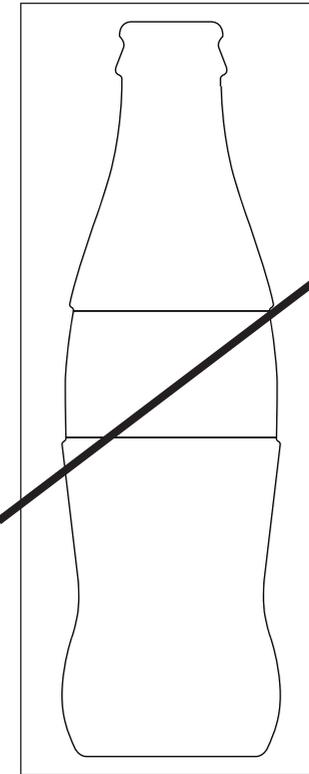

No Flutes
Aluminum packaging is excepted as Flutes are not technically feasible.

Flutes: Do's and Don'ts (section)

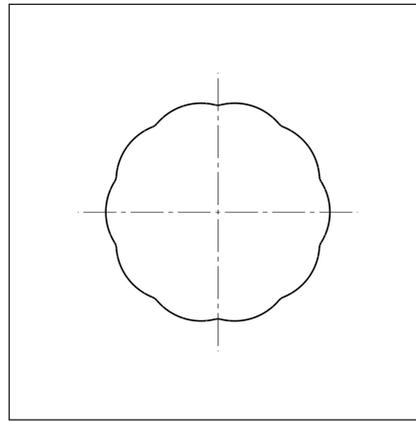
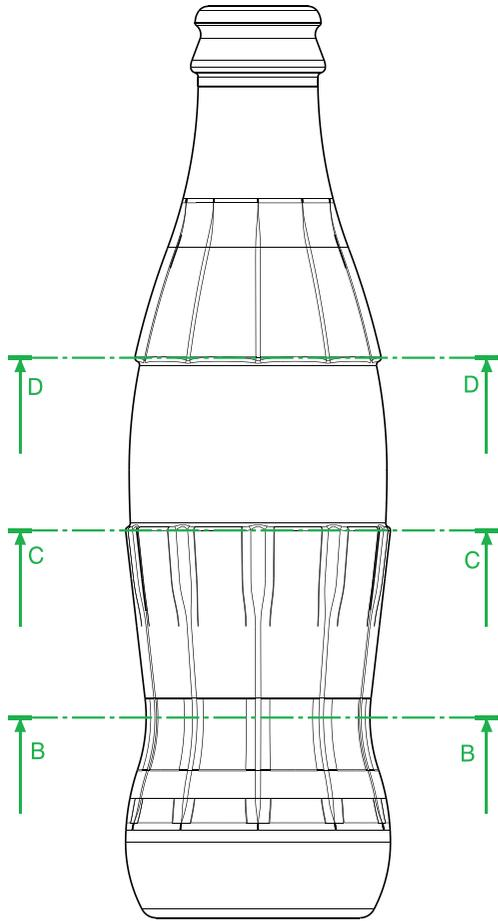

Section B

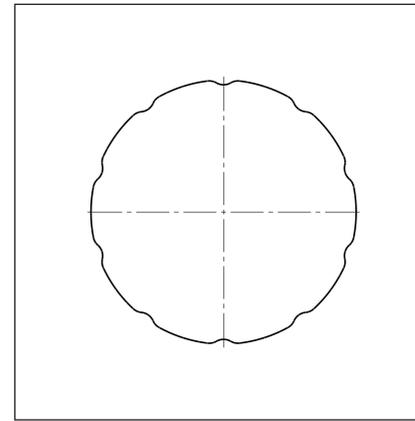

Section C

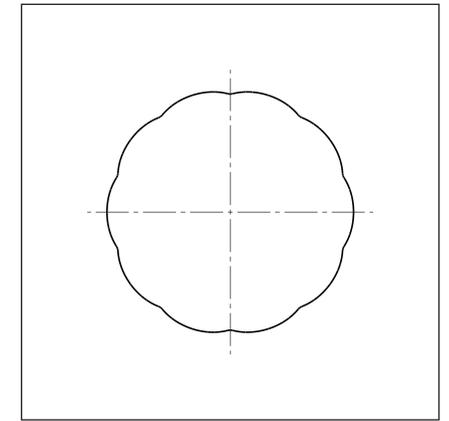

Section D

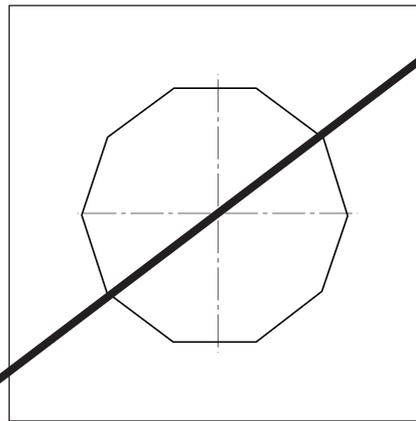

Flat

Do not use flat surfaces to define Flutes, as the form will seem faceted and sharp.

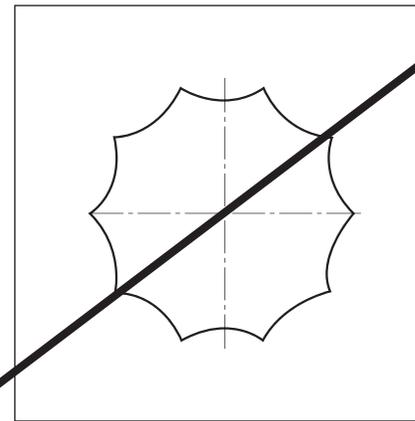

Concave

Do not use inward-arching Flutes as they decrease hand comfort and hinder high-speed conveyance.

Pinch Waist: Do's and Don'ts (format)

Correct

A flowing, symmetrical Pinch Waist that is defined by arc(s).

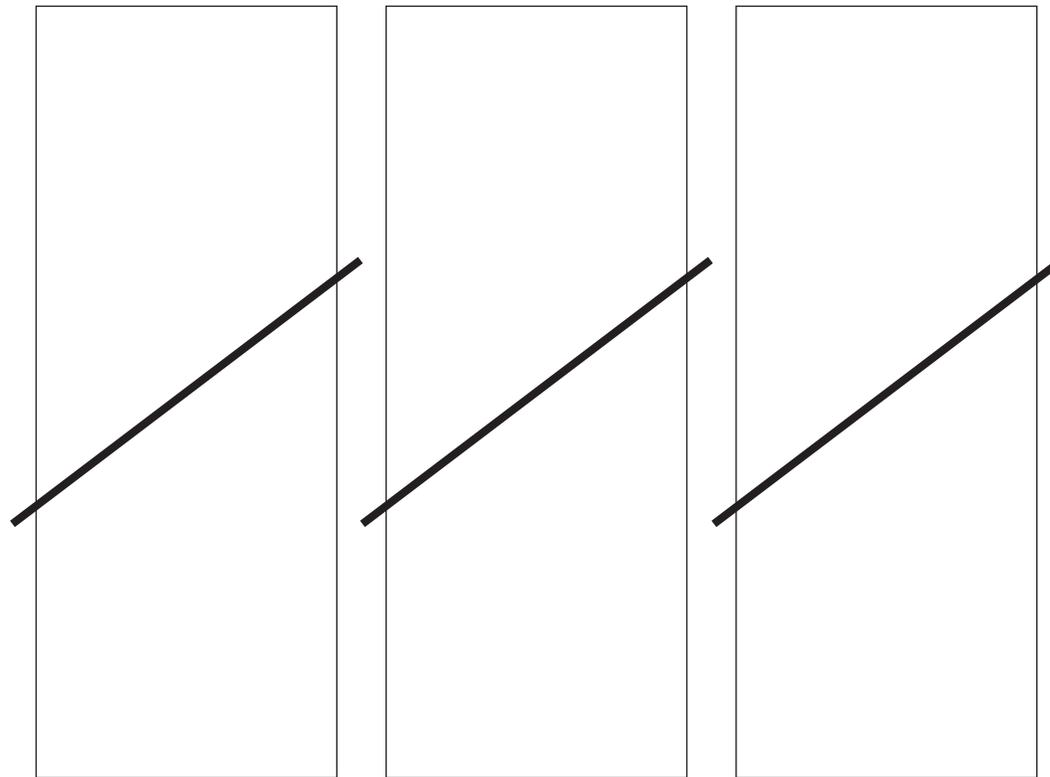

Angled

Do not use an angular Pinch Waist.

Asymmetrical

Do not use an asymmetrical Pinch Waist.

Mid Pinch Area

Do not eliminate the iconic quality of the Pinch Waist.

Executorial Constraints for Glass, PET and Aluminum

When creating Contour Bottle executions in glass, PET and aluminum, differences in material properties and manufacturing requirements must be considered so that Defining Features are not degraded or lost. The following pages address how to successfully manage these constraints.



Material and Process Considerations

The five primary limitations that can be encountered in creating iconic packaging are:

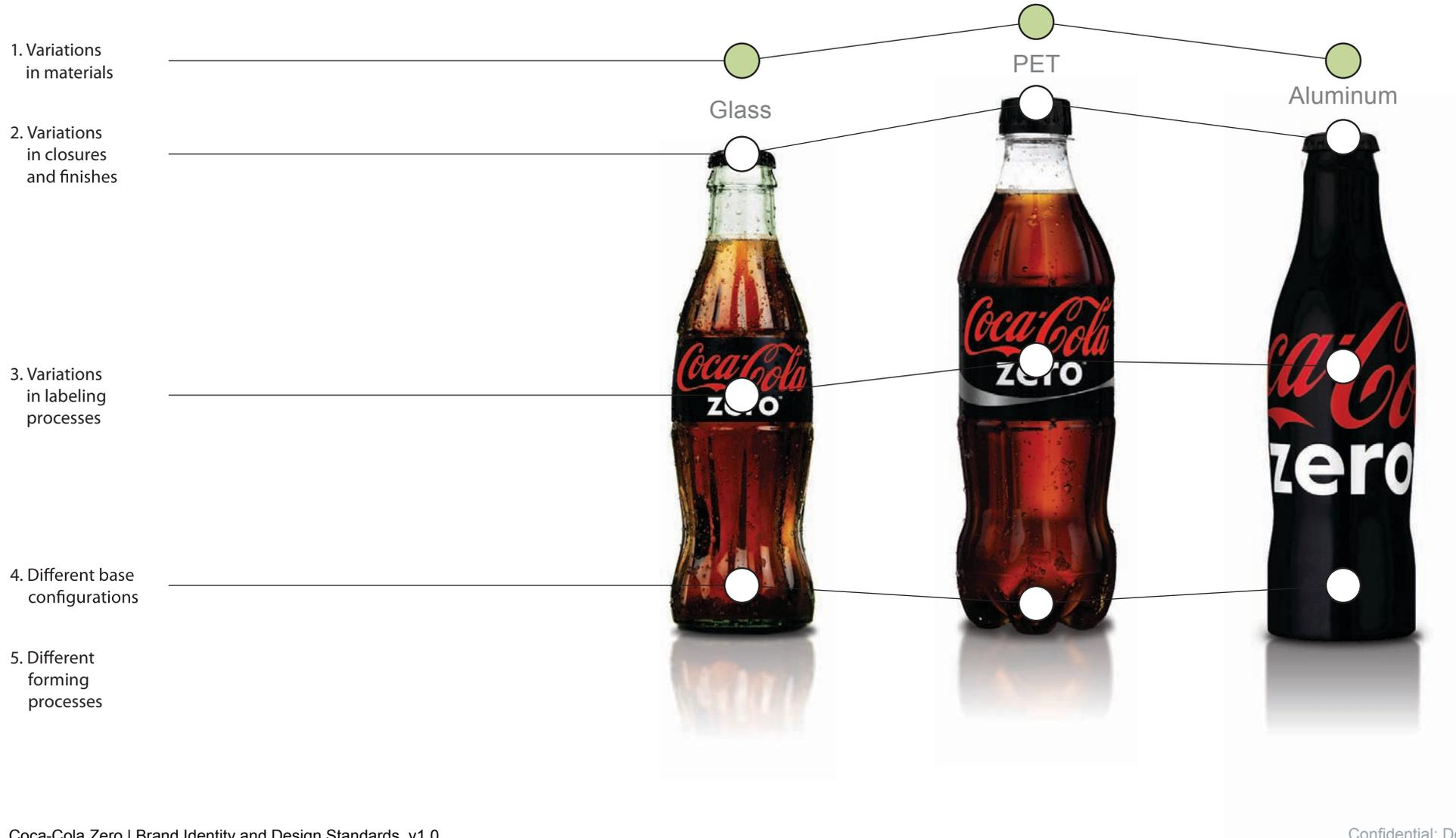

Material and Process Considerations

Manufacturing processes, filling and capping, efficiencies and cost, and limitation of current technology are all factors that determine what features and details are achievable for each of these three materials. In particular, keep these considerations top of mind:



- Crimped metal closure
- Large neck finish
- Screen-printed labeling (non-ruled surface)

1. Glass has the ability to offer all of the iconic defining features and must be implemented in all Contour Bottle executions.



- Plastic closure with tamper ring
- Thin transfer neck ring
- Paper or plastic wrap labels (ruled surface)

1. The petaloid base on a PET Bottle allows us to minimize the gram weight of the Bottle and maintain the shape under pressure created by the product. The Champagne Base can be attained, but requires a heavier Bottle.
2. Since carbonation can distort surface details of the thinner, softer walls of PET Bottles, ensure a well-defined Flute shape by giving the divisions more structure.
3. Unlike on the more fragile glass Bottle, the PET neck ring can be thinner, thus allowing less material to be used.
4. Use a twist-on cap for PET Bottles, as a crown cap is not effective at holding carbonation in a PET Bottle.
5. Avoid tinted plastics as they are not as cost effective as clear resins.



- Crimped metal closure
- Minimal neck finish
- 4-color pad-printing and varnishing process (non-ruled surface)

1. Do not attempt Flutes or Scalloped transitions. They are not achievable for the aluminum Contour Bottle due to the impact extrusion and necking processes used.
2. A variation from the standard curve of the Champagne Base will occur during the aluminum forming process. This results from the creation of a flat area at the base of the Bottle where the material is too thick to be formed from the original cylindrical shape that is created from the impact extrusion.
3. Print the aluminum Contour Bottle just like a standard can, using a pad-printing process before the form is created. The resulting full graphic coverage of the package is an approved exception for this material only, since on glass and PET the product must be showcased through their transparent materials.

Overview of Executorial Constraints

	 Possible	 Not Possible	 Challenging
			
Black Cap			
Silhouette			
Flutes			
Georgia Green Color			
Curved Label Panel			
Pinch Waist			
Neck Finish			
Embossed Coca-Cola Zero Logo			
Black Label			
Visible Product (brown color)			
Champagne Base			

Point-of-Sale Design Standards

4.0

(Work in Progress, coming 2010)

Equipment Design Standards

5.0

(Work in Progress, coming 2010)

Signage Design Standards

6.0

Contents

- Overview 6.02
- Permanent Signage Graphic Principles6.03
- Square Format
 - Square Format: Arden Square 6.04
 - Square Format: Contour Bottle6.05
- Horizontal Format
 - Horizontal Format: Coca-Cola Zero Logo and Contour Bottle..... 6.06
 - Horizontal Format: Customizable Signs.....6.07
- Vertical Format: Customizable Signs6.08
- Pitch Boards.....6.09
 - Horizontal Format: Pitch Boards6.10
- Umbrellas 6.11

Overview

The purpose of permanent signage for Coca-Cola Zero is both simple and paramount: to tell people, "You can buy Coca-Cola Zero here." Thus the Coca-Cola Zero Permanent Sign System is an essential component of worldwide Brand Identity and meaning.

From a tactical standpoint, proper application of the Sign System is vital to protecting and increasing Brand impact, consistency, scale and cultural relevance. The standards in this chapter provide guidance for leveraging them all, in particular:

- Applying graphics to permanent signage in specific environments, and
- Maximizing the visibility of graphics to accommodate variations in sign size, location and traffic approach.

Approved digital files of the Core Brand Elements, customizable graphics and design templates for signage are available on the Design Machine website at www.coca-coladesignmachine.com. Please use only the approved versions supplied there.



Permanent Signage: Graphic Principles

The design of permanent signs must always follow a graphic archetype that is iconic, bold, simple and without Brand messaging. This timeless approach:

- Provides a mainstay of Brand Identity within the totality of touchpoints,
- Leverages the typically long display life of permanent signs, and
- Prompts consumption and top-of-mind awareness before the shopper forms a consideration list.

The graphic archetype for permanent signage reflects the following:

- The Coca-Cola Zero Design Principles of Bold Simplicity and the Power of Black
- Discerning use of these Core Brand Elements, as shown in this chapter:
 - Coca-Cola Zero Logo
 - Dynamic Ribbon
 - Contour Bottle (iconic Symbol or Photo)
 - Black
- Standard formats for conventional signage, as shown in this chapter:
 - Square
 - Horizontal
 - Vertical
- The importance of creating shopper awareness from 6 meters (about 20 feet) away.

The remaining pages in this chapter provide standards for applying the archetype to key formats and types of permanent signage.

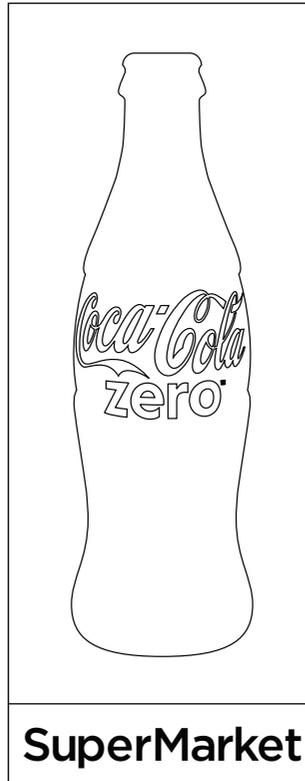
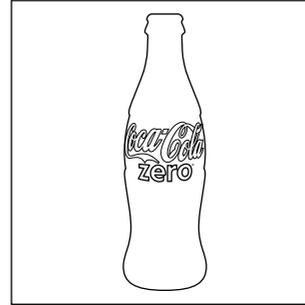
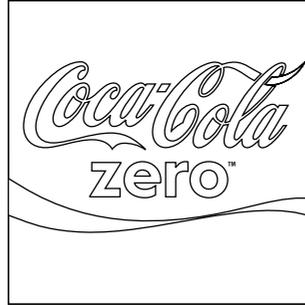

Square Format: Arden Square

The ingenious design of the Arden Square, which blends three distinctive Coca-Cola Zero Core Brand Elements (Coca-Cola Zero Logo, the Dynamic Ribbon and black), is ideal for permanent signage with a square format.

Always apply the Design Standards for the Arden Square as provided in the Core Brand Elements and Standards chapter (2.0). In particular:

- Maintain proper scaling of the Arden Square when resizing it.
- The background color must always be black; the Coca-Cola Zero Logo must be Coke Red and White; The Dynamic Ribbon must be silver.
- No other colors, even if they're in the Brand color palette, are to be used.
- Never add borders or outlines around the Arden Square.
- Apply the Coca-Cola Zero Logo and TM scaling rules as specified on the 'Clear Space, Minimum Size, TM Scaling, Cropping' page in the Core Brand Elements and Standards chapter (2.0).

Use only the approved versions of the Arden Square available on the Design Machine website.

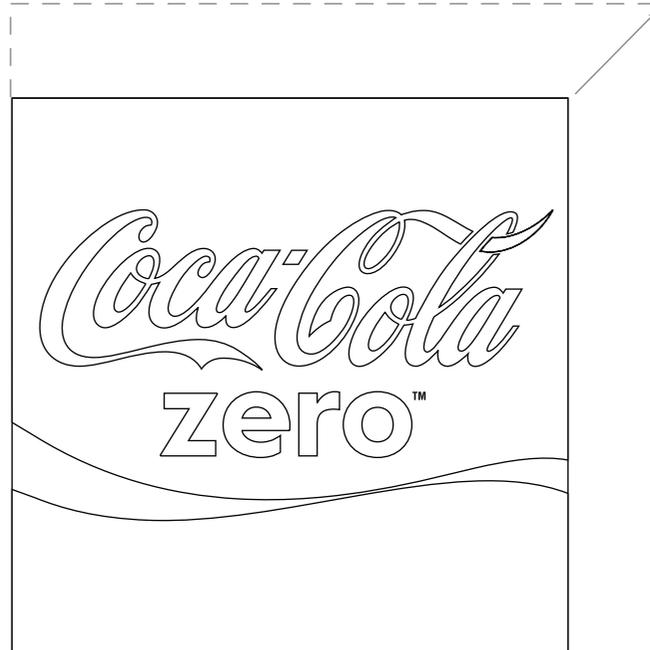

Square Format: Contour Bottle

The bold simplicity of this global icon is well suited for this format.

Always apply the Design Standards for the Contour Bottle (iconic Symbol or Photo) as provided in the Core Brand Elements and Standards chapter (2.0). In particular:

- Surround the Contour Bottle with clear space that is, at a minimum, the x-height of the “a” in “Coca.” This clear space area is shown to the right as ‘x.’
- Never use a 2D Coca-Cola Zero Logo on the Contour Bottle Symbol.
- The Contour Bottle must always be shown in its entirety and never be cropped.
- The shape of the Contour Bottle must always remain the same.
- Maintain proper scaling of the Contour Bottle when resizing it.
- The background color must always be black; the Contour Bottle Symbol must be white with the Coke Red and black Coca-Cola Zero Logo. No other colors, even if they’re in the Brand color palette, are to be used.
- The Contour Bottle Symbol is the preferred artwork, but the Contour Bottle Photo may be utilized when refreshment cues are necessary.

Use only the approved versions of the Contour Bottle Symbol and the Contour Bottle Photo available on the Design Machine website.

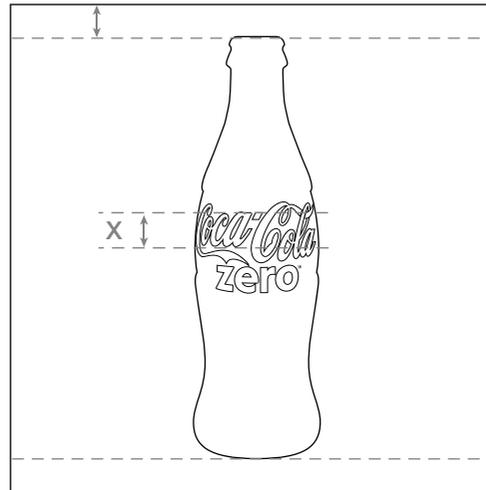

Clear Space



Horizontal Format: Coca-Cola Zero Logo and Contour Bottle

Distinctive, elegant and dynamic, the Coca-Cola Zero Logo is a natural fit for horizontal-format executions that do not include custom messaging (e.g., a store name). The preferred design approach features both the Coca-Cola Zero Logo and the Contour Bottle as shown.

Always apply the Design Standards for the Coca-Cola Zero Logo and the Contour Bottle (iconic Symbol or Photo) as provided in the Core Brand Elements and Standards chapter (2.0). In particular:

- Surround the Coca-Cola Zero Logo with clear space that is, at a minimum, “hyphen height;” i.e., equal to the height of the hyphen connecting “Coca” and “Cola.”
- Never crop the Coca-Cola Zero Logo.
- The Coca-Cola Zero Logo and Contour Bottle should be of equal height.
- The Contour Bottle must always be shown in its entirety and never be cropped.
- Never use a 2D Coca-Cola Zero Logo on the Contour Bottle Symbol.
- Maintain proper scaling of the Contour Bottle and the Coca-Cola Zero Logo when resizing them.
- The background color must always be black; the stand alone Coca-Cola Zero Logo must be Coke Red and black; the Contour Bottle Symbol must be white with the Coke Red and black Coca-Cola Zero Logo. No other colors, even if they’re in the Brand color palette, are to be used.
- The Contour Bottle Symbol is the preferred artwork, but the Contour Bottle Photo may be utilized when refreshment cues are necessary.

Use only the approved versions of the Coca-Cola Zero Logo, the Contour Bottle Symbol and the Contour Bottle Photo available on the Design Machine website.

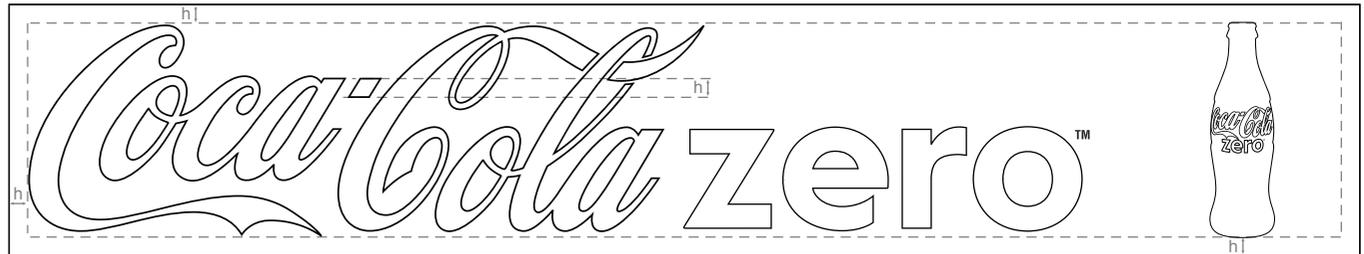

Clear Space



Horizontal Format: Customizable Signs

This format can be adapted to include simple customer messaging (e.g., a store name) by book-ending the sign with the square-format designs as shown at right and specified below.

Always apply the Design Standards for the Arden Square and Contour Bottle (iconic Symbol or Photo) as provided in the Core Brand Elements and Standards chapter (2.0).

- The height of the sign must be equal to the height of the Arden Square.
- For executions more than 2 meters (about 6 ½ feet) wide, utilize a square-format design on each end that features the Arden Square only or in combination with the Contour Bottle.
- For executions less than 2 meters wide, utilize a square-format design on each end that features the Arden Square only.
- Maintain proper scaling of the Arden Square and Contour Bottle when resizing them.
- Maintain the Coca-Cola Zero color standards for the Arden Square and Contour Bottle; the background color for the customizable area must always be white.
- The Contour Bottle Symbol is the preferred artwork, but the Contour Bottle Photo may be utilized when refreshment cues are necessary.
- The text of the custom message should be set in the Gotham Medium font. Refer to the Typography section in the Core Brand Elements and Standards chapter (2.0) for typography usage standards.



Use this version only for executions less than 2 meters (about 6 ½ feet) wide.



Use this version only for executions more than 2 meters wide.

Vertical Format: Customizable Signs

Use the Contour Bottle, with its distinctive curvilinear form, for executions of this format.

Always apply the Design Standards for the Contour Bottle (iconic Symbol or Photo) as provided in the Core Brand Elements and Standards chapter (2.0).

- Always place the customizable area at the bottom of the sign.
- The text of the custom message should be set in the Gotham Medium font. Refer to the Typography section in the Core Brand Elements and Standards chapter (2.0) for typography usage standards.
- The customizable area must extend the full width of the sign while not exceeding one quarter of the total sign height.
- Surround the Contour Bottle with clear space that is, at a minimum, the x-height of the “a” in “Coca.” This clear space area is shown to the right as ‘x.’
- The Contour Bottle must always be shown in its entirety and never be cropped.
- The shape of the Contour Bottle must always remain the same.
- Maintain proper scaling of the Contour Bottle when resizing it for various sign dimensions.
- Never use a 2D Coca-Cola Zero Logo on the Contour Bottle Symbol.
- The background color must always be black; the Contour Bottle Symbol must be white with the Coke Red and black Coca-Cola Zero Logo. No other colors, even if they’re in the Brand color palette, are to be used.
- The Contour Bottle Symbol is the preferred artwork, but the Contour Bottle Photo may be utilized when refreshment cues are necessary.

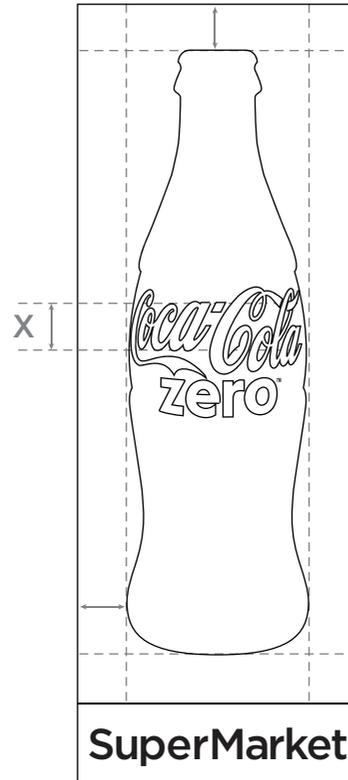

Clear Space



Pitch Boards

Pitch boards offer a high-visibility, repeat-impression touchpoint for the Brand in sports venues and stadiums. Applying the Design Principle of Bold Simplicity is key for signage in these environments, as all boards need to:

- Create on-site awareness from 30-40 meters (about 120 feet) away.
- Maximize impact when viewed at a distance, whether live or on television.
- Be consistent in appearance, regardless of size variations across venues.

Use the precisely optimized compositions of the Coca-Cola Zero Logo and Contour Bottle (iconic Symbol or Photo), provided on the next page, for Pitch Board designs.



Horizontal Format: Pitch Boards

Always apply the Design Standards for the Coca-Cola Zero Logo and the Contour Bottle (iconic Symbol or Photo) as provided in the Core Brand Elements and Standards chapter (2.0).

- To ensure a quick and easy read from a distance, do not include any Brand messaging on Pitch Boards.
- Surround the Coca-Cola Zero Logo with clear space that is, at a minimum, “hyphen height;” i.e., equal to the height of the hyphen connecting “Coca” and “Cola.”
- Never crop the Coca-Cola Zero Logo.
- The Contour Bottle must always be shown in its entirety and never be cropped.
- Never use a 2D Coca-Cola Zero Logo on the Contour Bottle Symbol.
- Maintain proper scaling of the Contour Bottle and the Coca-Cola Zero Logo when resizing them to fit umbrellas.
- The preferred background color is black, but in venues where black is not allowed, a white background with the Coke Red and black Coca-Cola Zero Logo and a white Contour Bottle Symbol may be used.
- The Contour Bottle Symbol is the preferred artwork, but the Contour Bottle Photo may be utilized when refreshment cues are necessary.



5:1 Ratio



10:1 Ratio

Umbrellas

Always apply the Design Standards for the Coca-Cola Zero Logo and the Contour Bottle (iconic Symbol or Photo) as provided in the Core Brand Elements and Standards chapter (2.0).

- To ensure a quick and easy read from a distance, do not include any Brand messaging on umbrellas.
- Surround the Coca-Cola Zero Logo with clear space that is, at a minimum, “hyphen height;” i.e., equal to the height of the hyphen connecting “Coca” and “Cola.”
- Never crop the Coca-Cola Zero Logo.
- The Contour Bottle must always be shown in its entirety and never be cropped.
- Never use a 2D Coca-Cola Zero Logo on the Contour Bottle Symbol.
- Maintain proper scaling of the Contour Bottle and the Coca-Cola Zero Logo when resizing them to fit umbrellas.
- The preferred background color is black, but in venues where black is not allowed, a white background with the Coke Red and black Coca-Cola Zero Logo and a white Contour Bottle Symbol may be used.
- The Contour Bottle Symbol is the preferred artwork, but the Contour Bottle Photo may be utilized when refreshment cues are necessary.

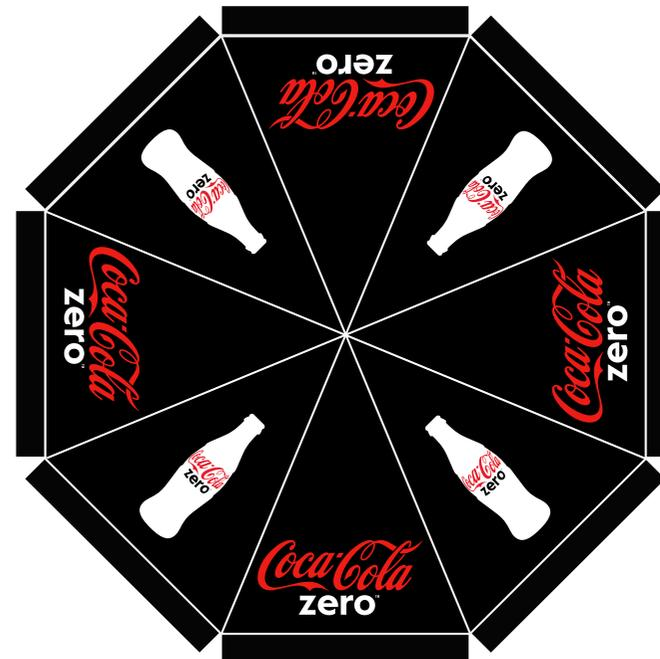

Fleet Design Standards

7.0

Contents

Overview 7.02

Fleet: Graphic Archetype 7.03

Fleet: Graphic Standards 7.04

Fleet: Paint Color Standards 7.05

Fleet: Application Standards for Graphics and Decals 7.06

 Delivery Truck Sides 7.07

 Delivery Truck Front 7.08

 Delivery Truck Rear 7.09

 Route Trucks 7.10

 Event Trailers 7.11

 Automobiles 7.12

 Pickup Trucks 7.13

 Vans 7.14

Overview

By virtue of their size, fleet graphics are some of the Brand's most visible expressions of identity. Since our System both owns and controls this potent medium, fleet graphics bring ample opportunity – and responsibility – to maximize their impact.

This chapter provides the standards for doing so, in particular:

- Applying graphics in a proper, consistent manner to all fleet vehicles (trucks, vans and automobiles), and
- Ensuring that fleet graphics continuously and consistently connect with consumers, whatever the environment and circumstance.

Approved digital files of the Core Brand Elements and customizable graphics for Fleet are available on the Design Machine website at www.coca-coladesignmachine.com. Please use only the approved versions supplied there.



Fleet: Graphic Archetype

The design of fleet graphics must always follow an established archetype that is iconic, bold, simple and without Brand messaging. This approach:

- Ensures that all vehicles used by Bottlers of The Coca-Cola Company make a unified visual impression.
- Ensures that the Brand Identity is experienced consistently within the totality of touchpoints.
- Maximizes impact at all times, even when both our vehicles and consumers are in motion relative to each other.
- Provides a simple, uniform approach for implementation.

The archetype for fleet graphics is based upon the following:

- A. The Coca-Cola Zero Design Principles of Bold Simplicity and the Power of Black.
- B. Discerning use of these Core Brand Elements, as shown in this chapter:
 - Coca-Cola Zero Logo
 - Contour Bottle (iconic Symbol or Photo)
 - Black and Coke Red

The following pages in this chapter provide standards for applying the archetype to key types and sizes of fleet vehicles.



Fleet: Graphic Standards

These graphic standards apply to all trucks and vehicles used by Bottlers of The Coca-Cola Company.

In General

- Do not include any Brand messaging on fleet graphics.
- Always apply the Design Standards for the Coca-Cola Zero Logo and Contour Bottle (iconic Symbol or Photo) as provided in the Core Brand Elements and Standards chapter (2.0).
- The background color must always be black and the color standards for the Coca-Cola Zero Logo and Contour Bottle always apply. No other colors, even if they're in the Brand color palette, are to be used.
- Apply the standards specific to each type of vehicle, per the following pages.

Coca-Cola Zero Logo

- Surround the Coca-Cola Zero Logo with clear space that is, at a minimum, "hyphen height;" i.e., equal to the height of the hyphen connecting "Coca" and "Cola."
- Never crop the Coca-Cola Zero Logo.
- Maintain proper scaling when resizing the Coca-Cola Zero Logo by following the graphic references included in this section and scaling rules specified on the 'Clear Space, Minimum Size, TM Scaling, Cropping' page in the Core Brand Elements and Standards chapter (2.0).

Contour Bottle

- Use the Contour Bottle Symbol or Contour Bottle Photo only as specified on the following pages.
- The Contour Bottle must always be shown in its entirety and never be cropped.
- Never use a 2D Coca-Cola Zero Logo on the Contour Bottle Symbol.
- Maintain proper scaling when resizing the Contour Bottle by following the graphic references included in this section and scaling rules specified on the 'Clear Space, Minimum Size, TM Scaling, Cropping' page in the Core Brand Elements and Standards chapter (2.0).

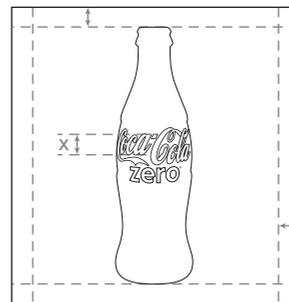
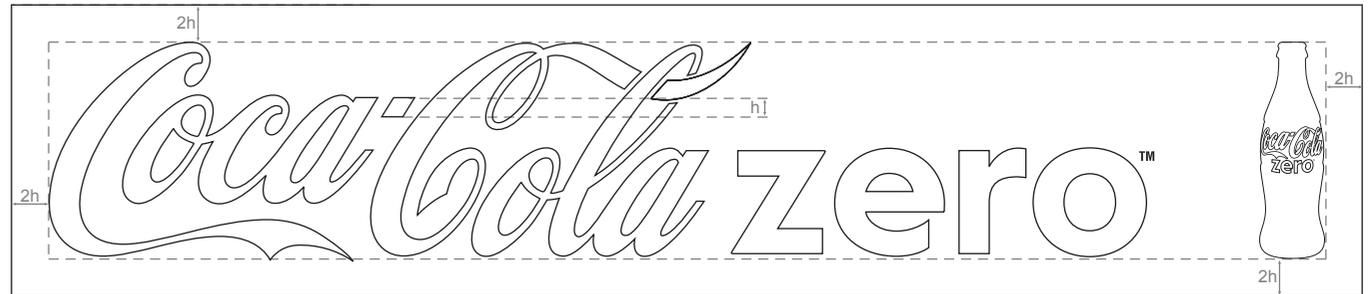

Clear Space

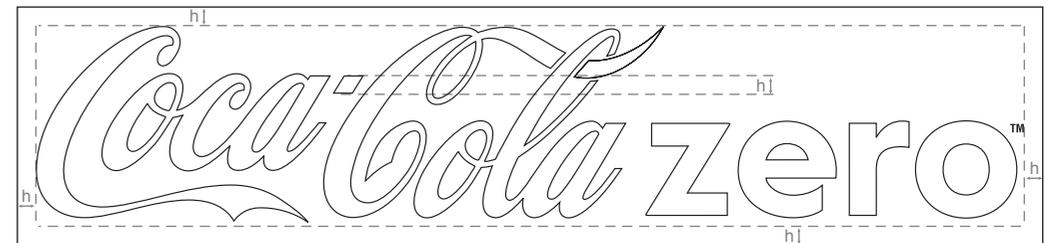

Fleet: Application Standards for Graphics and Decals

Graphics for fleet application support the overall Brand Identity through visual consistency across the globe while accommodating variations in vehicle types and styling.

In General

- Follow the carefully developed standards provided here to ensure a uniform visual impression.
- Specific standards for delivery trucks, route trucks, event trailers, automobiles, pickup trucks and utility vans are provided on the following pages.
- Maintain proper scale of the provided graphics when resizing them for various vehicle sizes.

Vinyl Decals

Vinyl decals are the preferred means by which to render the Coca-Cola Zero Logo and Contour Bottle (iconic Symbol or Photo) onto fleet vehicles. Affix the decals according to their application instructions.

To determine the appropriate decal size for the Coca-Cola Zero Logo and Contour Bottle:

1. Measure, from top to bottom, the black space onto which the decal will be applied (i.e., the side body panel of a trailer, the door panel of a pickup truck).
2. Calculate the size of the decal so that its height is approximately 50.8 - 76.2 mm (2 - 3 inches) less than the total height of the black space.
3. While the ideal clear space around decals is approximately 50.8 - 76.2 mm (2 - 3 inches), make sure the minimum clear space is in any case at least equal to the height of the hyphen in the Coca-Cola Zero Logo.

Painted Graphics

- Only the Coca-Cola Zero Logo and Contour Bottle Symbol may be painted.
 - Never paint the Contour Bottle Photo.
- Only one stencil size of the Coca-Cola Zero Logo and Contour Bottle Symbol is required for each vehicle size in the fleet.
 - Create a custom stencil for each graphic, using heavy gauge, transparent Mylar plastic.
 - Follow the size and clearspace guidelines for vinyl decals.

Delivery Truck Sides

Fleet graphics on large delivery trucks serve as mobile billboards.

Trailer Side Graphics

- Show the Coca-Cola Zero Logo and Contour Bottle on both sides of the trailer.
 - Use either the Contour Bottle Symbol or Contour Bottle Photo on delivery trucks, but never both on the same panel.
- Position the Coca-Cola Zero Logo on the far left side of the trailer; position the Contour Bottle upright on the far right side of the trailer.
 - The space between the Coca-Cola Zero Logo and Contour Bottle will vary with the trailer length.
- Both graphics should be of equal height.

Side Cab Graphics

- Show the Coca-Cola Zero Logo on both sides of door panels of the cab portion of the truck.
- Centrally position the Bottler's name, address and any identifiers required by law beneath the Coca-Cola Zero Logo.

Refer to the prior page, 'Application Standards for Graphics and Decals,' as needed.



Delivery Truck Front

Front Graphic

- Center the Coca-Cola Zero Logo in the black space on the “cab over” portion above the windshield.
- Since the Coca-Cola Zero Logo is the only graphic identification when the truck is viewed directly from the front, be sure to maximize its visibility above the cab.

Refer to the prior page, ‘Application Standards for Graphics and Decals,’ as needed.



Delivery Truck Rear

Rear Graphic

- The Contour Bottle is the preferred graphic for the rear panel of the truck.
 - Use either the Contour Bottle Symbol or Contour Bottle Photo on delivery trucks, but never both on the same panel.
- Position the Contour Bottle upright and centered in the black space, ensuring equal space on each side of the decal.
- If vertical space is limited (e.g., trucks with lift gates), the Coca-Cola Zero Logo may be used instead, centered in the black space with equal space on each side of the decal.

Refer to the prior page, 'Application Standards for Graphics and Decals,' as needed.



Route Trucks

Side Graphics

- Show the Coca-Cola Zero Logo and the Contour Bottle on both sides of the trailer.
 - Use either the Contour Bottle Symbol or Contour Bottle Photo on route trucks, but never both on the same panel.
- Position the Coca-Cola Zero Logo on the far left side of the trailer; position the Contour Bottle upright on the far right side of the trailer.
 - The space between the Coca-Cola Zero Logo and Contour Bottle will vary with the trailer length.
- Both graphics should be of equal height.



Front Graphic

- Center the Coca-Cola Zero Logo in the black space on the “cab over” portion above the windshield.
- As the Coca-Cola Zero Logo is the only graphic identification when the truck is viewed directly from the front, be sure to maximize its visibility above the cab.

Rear Graphic

- The Contour Bottle is the preferred graphic for the rear panel of the trailer.
 - Use either the Contour Bottle Symbol or Contour Bottle Photo on route trucks, but never both on the same panel.
- Position the Contour Bottle upright and centered in the black space, ensuring equal space on each side of the decal.
- If vertical space is limited (e.g., trucks with lift gates), the Coca-Cola Zero Logo may be used instead, centered in the black space with equal space on each side of the decal.

Refer to the prior page, ‘Application Standards for Graphics and Decals,’ as needed.

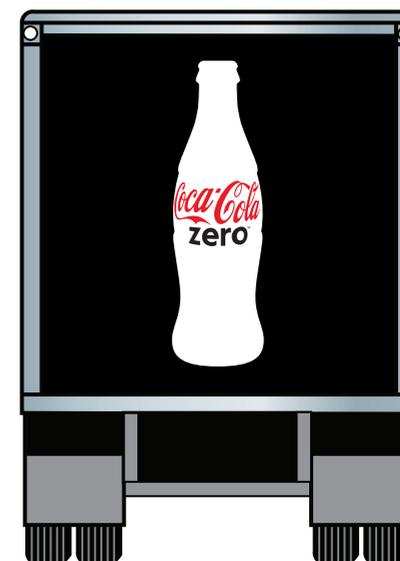

Event Trailers

Side Graphics

- Show the Coca-Cola Zero Logo and Contour Bottle on both sides of the trailer.
 - Use either the Contour Bottle Symbol or Contour Bottle Photo on event trailers, but never both on the same panel.
- To ensure that the Coca-Cola Zero Logo is always visible, position it on the panel below the window panel that lifts up.
- Show the Contour Bottle on the vertical panel that is alongside the window panel. Position it upright and centered in the Coke Red space of this panel.

Front Graphic

- Center the Coca-Cola Zero Logo in the black space above the hitch portion of the trailer.
- As the Coca-Cola Zero Logo is the only graphic identification when the truck is viewed directly from the front, be sure to maximize its visibility above the vehicle pulling it.

Rear Graphic

- Position the Contour Bottle upright on the rear door of the trailer. Center it in the black space, ensuring equal space on each side of the decal.
 - Use either the Contour Bottle Symbol or Contour Bottle Photo on event trailers, but never both on the same panel.

Refer to the prior page, 'Application Standards for Graphics and Decals,' as needed.

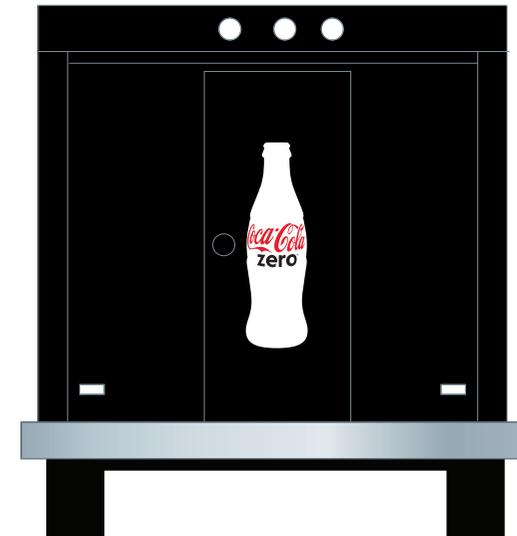

Automobiles

Side Graphics

- Show the Coca-Cola Zero Logo and the Contour Bottle on both sides of the automobile.
 - Use either the Contour Bottle Symbol or the Contour Bottle Photo on automobiles, but never both on the same panel.
- Both graphics should be of equal height.
- Position both graphics in the area between the front and back wheels and below the side windows, with:
 - Coca-Cola Zero Logo on the far left side, and
 - The Contour Bottle upright on the far right side.
- The space between the Coca-Cola Zero Logo and Contour Bottle will vary with the automobile length.



Front Graphic

- Centrally position the Coca-Cola Zero Logo in the black space of the hood, ensuring equal space on each side of the decal.
- As the Coca-Cola Zero Logo is the only graphic identification when the automobile is viewed directly from the front, be sure to maximize its visibility on the hood.

Rear Graphics

- Position the Coca-Cola Zero Logo on the left side of the bumper.
- Position the Contour Bottle on the right side of the bumper.
- Both graphics should be of equal height.

Refer to the prior page, 'Application Standards for Graphics and Decals,' as needed.



Pickup Trucks

Side Graphics

- Show the Coca-Cola Zero Logo and Contour Bottle on both sides of the truck.
 - Use either the Contour Bottle Symbol or the Contour Bottle Photo on pickup trucks, but never both on the same panel.
- Both graphics should be of equal height.
- Centrally position the Coca-Cola Zero Logo in the area between the front and back wheels and below the side window.
- Position the Contour Bottle upright between the back wheel and bumper.



Front Graphic

- Centrally position the Coca-Cola Zero Logo in the black space of the hood, ensuring equal space on each side of the decal.
- As the Coca-Cola Zero Logo is the only graphic identification when the truck is viewed directly from the front, be sure to maximize its visibility on the hood.

Rear Graphics

- Position the Coca-Cola Zero Logo on the far left side of the truck gate.
- Position the Contour Bottle upright on the far right side of the gate.
- Both graphics should be of equal height.

Refer to the prior page, 'Application Standards for Graphics and Decals,' as needed.



Vans

Side Graphic with Visible Cargo Windows

- Show the Coca-Cola Zero Logo and the Contour Bottle on both sides of the van.
 - Use either the Contour Bottle Symbol or Contour Bottle Photo on vans, but never both on the same panel.
- Centrally position the Coca-Cola Zero Logo in the area between the front and back wheels and below the side window (driver/front passenger).
- Position the Contour Bottle upright between the back wheel and bumper.
- Both graphics should be of equal height.



Side Graphic with No or Painted Cargo Windows

- Centrally position the Coca-Cola Zero Logo in the area between the side window (driver/front passenger) and the back edge of the van.
- Position the Contour Bottle upright on the side door (driver/front passenger).
- Both graphics should be of equal height.



Front Graphic

- Centrally position the Coca-Cola Zero Logo in the black space of the hood. Ensure:
 - Equal space on each side of the decal.
 - That the bottom edge of the decal is approximately 38.10 mm (1.5 inches) above the seam where the hood meets the grill.

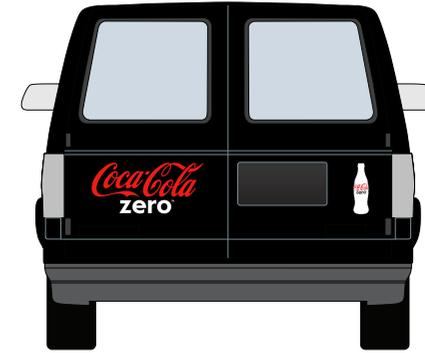

Rear Graphic

- Position the Coca-Cola Zero Logo on the far left side of the left rear door.
- Position the Contour Bottle upright on the far right side of the right rear door.
- Both graphics should be of equal height.

Refer to the prior page, 'Application Standards for Graphics and Decals,' as needed.

Trademark Usage Requirements

8.0

Trademark Policies of The Coca-Cola Company

Our trademarks include some of the best-known and most well-recognized trademarks in the world. As a result, our trademarks are among the most valuable assets of TCCC. If they are used properly, TCCC's valuable and distinctive trademarks can be kept forever. However, with improper use, we run the risk of losing one or more of our trademarks altogether.

Because of the importance of TCCC's trademarks, it is the policy of TCCC that all employees of TCCC must help safeguard its trademarks and be aware of the rules and guidelines for proper use of TCCC's trademarks. These policies and procedures for trademark protection and use should be followed to ensure consistent use and continued protection of our trademarks. The policies apply regardless of whether a proposed use of TCCC's trademarks is internal or external.

There are a number of trademark use rules that apply to all of TCCC's trademarks. Consistent use of TCCC's marks in accordance with these rules strengthens the rights in TCCC's marks and enhances their value. Exceptions, rarely, if ever, should be made. If you believe that an exception to any of these rules is appropriate, advance approval must be obtained. These rules include the following:

A trademark should, whenever possible, be used as an adjective and followed by a generic term, so that it is clear that the trademark refers to a specific product that is of a particular type.

Example: Drink COCA-COLA ZERO soft-drinks.

If the context is clear that the reference is to a specific product of TCCC identified by the trademark, a trademark can also be used as a proper noun. Trademarks of TCCC,

well known and famous trademarks (such as COCA-COLA and COKE) can also be used as proper nouns. Example:

Correct : Enjoy a COKE ZERO.

Incorrect: I bought a ZERO yesterday.

If a trademark is used as a proper noun, care must be taken that the trademark is not used in a way that suggests that it is an everyday, generic term for a type of product. For this reason, use of a trademark as a proper noun should be evaluated on a case-by-case basis by appropriate TCCC Trademark Counsel.

Use of our trademarks in the possessive or plural forms is discouraged, and all such uses must be approved by the appropriate TCCC Trademark Counsel. Example:

Correct: 2 Coca-Cola Zero products for \$4

Incorrect : 2 Coke Zeros for \$4

A trademark should never be used as a generic name for a category of products, or as a verb, a common noun, or any part of speech other than an adjective or a proper noun. Our rights to our trademarks are strengthened and maintained when we use them properly and do not suggest that they are common, everyday terms that can be used to refer to products of many companies.

In materials distributed outside TCCC, a trademark should, whenever possible, be displayed in a format that sets it apart from other text, makes it stand out, and indicates that it is a trademark, such as in all CAPITAL LETTERS, in "quotation marks," or in a special script, italics, or bold print.

Example: This store sells COKE, DIET COKE and COCA-COLA ZERO.

In creating slogans that include trademarks, do not use hyphens to link the trademarks to other words in the slogan.

Incorrect Example: Hoorah-Coca-Cola Zero.

Do not change in any way the spelling of a word mark. For example, do not change the spelling of "COCA-COLA ZERO" so that it reads "COKA-KOLA ZERO."

Beverage products should not be described as "original" or "genuine" or otherwise identified in a way that could suggest that others have similar products. Examples of such exceptions are: the phrase "Original Formula" used for COCA-COLA ZERO.

Brand Integrity Principles

There are certain trademark use principles that relate to the integrity of the brands in connection with which TCCC's trademarks are used. Those principles generally relate to making consistent use of trademarks in a particular way and avoiding "combining" the elements or identities of different brands. They are designed to ensure that TCCC's trademarks are used in ways that strengthen TCCC's rights in each of its trademarks.

For trademarks that have a particular typeface, font, presentation or design element associated with them, use only graphic presentations that are approved.

Presenting the trademark COCA-COLA in Spencerian script.



The image shows the Coca-Cola logo in its signature Spencerian script, with the word "zero" written below it in a bold, black, sans-serif font. A small trademark symbol (TM) is located to the right of the word "zero".

Trademark Policies of The Coca-Cola Company

Particular typefaces, fonts, presentations and design elements are generally associated with only one brand. Do not use elements that have been approved for one brand with a different brand. Example:

Correct: Using the Dynamic Ribbon Device with brand COCA-COLA ZERO.

Incorrect: Using the Dynamic Ribbon Device with brand FANTA.

Do not add any graphic or other design elements to an existing trademark of TCCC without approval for the use of those additional elements. For example, adding additional flourishes to the letters of COCA-COLA when it is presented in Spencerian script.

Certain of the containers and packaging used by TCCC are proprietary to TCCC and can serve as trademarks. You must never use the Contour Bottle on FANTA, ODWALLA, SPRITE or other products other than COCA-COLA brand beverages.

Slogans should be used only in connection with the product for which they are intended. Example:

Correct: Coca-Cola Zero, It's Possible.
Incorrect: Coke Zero, Obey Your Thirst.

There are many ways in which TCCC's trademarks can be adapted, modified and/or combined with other materials. Such variations can sometimes strengthen the original trademark, but could sometimes be potentially damaging for legal or other reasons. All such variations could result in the creation of a new trademark that could infringe the rights of other parties and therefore would need to be searched and cleared prior to use. For these reasons, it is important that all such proposed variations be submitted for approval to the appropriate TCCC Trademark Counsel prior to use.

The addition of a prefix or suffix to a trademark, or otherwise using an existing trademark as a "stem" for a new word or trademark is an improper variation. Example:

Incorrect: Using words or phrases such as "COKEVILLE" or "ZEROtastic."

Alteration of any of the words of a slogan trademark is an improper variation of the trademark. Example:

Incorrect: Using slogans such as "That is Possible" instead of "It's Possible."

There are many occasions when one or more of TCCC's trademarks is used together with trademarks owned by others. Such situations can arise in conjunction with sponsorship by TCCC of events or organizations (such as the Olympics or the FIFA World Cup), as part of joint promotional activities, and/or in advertising or other uses by parties that have a right to use our trademarks.

All uses of trademarks of TCCC together with trademarks owned by other companies should be reviewed and approved by the appropriate TCCC Trademark Counsel.

When a trademark of another party appears on packaging or in advertising for one of TCCC's beverage products, the relationship between the other party and TCCC must be clear from the context, and the materials must reflect that only TCCC's trademark is the trademark for the beverage product. All such uses must be reviewed by the appropriate TCCC Trademark Counsel or Operations Counsel, in accordance with the standard practice of your Group, so that clarifying language can be added if necessary.

With limited exceptions, legal lines must accompany our trademarks whenever a trademark of another party appears with one of our trademarks, whether on packaging, vending machines, the Internet or otherwise. Such legal lines must identify the trademarks owned by TCCC and assert TCCC's ownership of them.

Example: XYZ is a registered trademark of XYZ Associates, Inc. COCA-COLA ZERO and the Dynamic Ribbon Device are trademarks of The Coca-Cola Company.

Even in cases where the third party does not require a legal line, we still need to insert the appropriate TCCC legal line.

Every term in the corporate name "The Coca-Cola Company" should have the initial letter capitalized, including the letter "T" in the word "The."

The trademark "COCA-COLA ZERO" should always be presented as a unitary phrase, and the words "Coca" and "Cola" and "Zero" should not be split on different lines or separated. When using word processing programs, use a "non-breaking hyphen" for the hyphen in "COCA-COLA ZERO."

Spencerian script that is used for the "COCA-COLA" trademark should not be used for anything other than trademarks incorporating "COCA-COLA," "COKE," "DIET COKE," "COCA-COLA LIGHT" and "COCA-COLA ZERO" and the trade names of The Coca-Cola Company, its subsidiaries and its bottlers.

The hyphen in "COCA-COLA ZERO" is an integral part of the trademark. Always include the hyphen whenever the trademark is displayed, even if the materials on which the graphics are based are archival pieces that do not include the hyphen.

Do not suggest that the shape of the COCA-COLA Contour Bottle (or any other proprietary bottle) has a functional benefit. Refer to such bottles as containers or packaging that are distinctive and identify TCCC's products. Example: WRONG: "The shape of the Contour Bottle makes it easier to get a firm grip on the bottle."

Use the Dynamic Ribbon Device only in relation to the "COCA-COLA" family of beverages or as a reference to TCCC. Do not combine the Dynamic Ribbon Device with third-party trademarks to create a new design or trademark.

Identity Standards Management Team and Process

9.0

Contents

Standards Management Principles	9.02
Standards Management Process and Accountability	9.03
Brand Standards Council.....	9.04

Standards Management Principles

Principles for Alignment to Standards

- The Identity and Design Standards are meant to drive quality, consistency and productivity across the System worldwide.
- It is the responsibility of each entity described herein to work towards and have a plan for aligning to the Identity and Design Standards.
- An assessment process will be put in place so that, periodically, the Company can understand our progress.

Principles for Exceptions

- The Standards, as written, should be the overwhelming norm. Therefore, exceptions should be very limited.
- A request for an exception must have a valid Business Case and be planned in advance. No work outside of the Standards should be started until an approval has been granted.
- An exception may have a maximum presence in market of 3 months and may only be leveraged once per year.

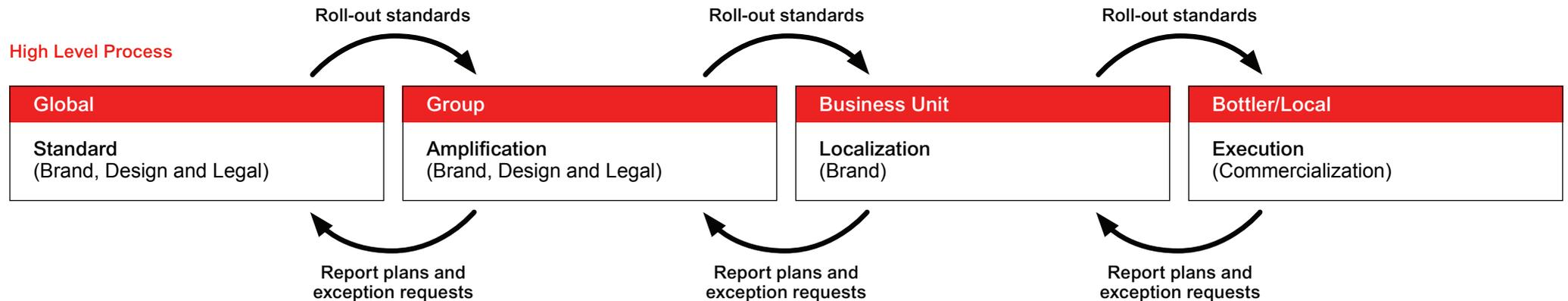

Standards Management Process and Accountability

Global	Group	Business Unit	Bottler/Local
<p>Standard (Brand, Design and Legal)</p>	<p>Amplification (Brand, Design and Legal)</p>	<p>Localization (Brand)</p>	<p>Execution (Commercialization)</p>
<ul style="list-style-type: none"> • Uphold and train Groups on Identity and Design Standards • Responsible for implementing Standards in Global Projects • Responsible for implementing and renewing Identity and Design Standards • Review and record exception requests from Groups • All Exception Rights are approved at Global 	<ul style="list-style-type: none"> • Uphold and train Business Units on Identity and Design Standards • Responsible for implementing Standards in Group Projects • Review and record exception requests from Business Units • Deny exception requests or approve for escalation to Global 	<ul style="list-style-type: none"> • Uphold and train Bottlers on Identity and Design Standards • Responsible for implementing Standards in Business Unit Projects • Review and record exception requests from Bottlers or other local entities • Deny exception requests or approve for escalation to Group 	<ul style="list-style-type: none"> • Responsible for implementing Standards in Bottler/Local Projects

Brand Standards Council

The following are the primary contacts for reporting roll-out and adoption plans for the Brand Standards. Where exception requests have a valid business case attached and will not live in market for more than 3 months, these contacts will also review exception requests as per their

roles defined on the previous pages. Emails to the Group should only come from that Group or Business Units within that Group.

Global	Group	Business Unit	Bottler/Local
<p>Standard (Brand, Design and Legal)</p>	<p>Amplification (Brand, Design and Legal)</p>	<p>Localization (Brand)</p>	<p>Execution (Commercialization)</p>
<p>Brand: Cristina Bondolowski, Derk Hendriksen</p> <p>Design: Todd Brooks, Lisa Motto, Vince Voron</p> <p>Legal: Danise van Vuuren-Nield, Bernadette Drankoski</p>	<p>EUG Brand: Regina Wurz-Janssens EUG Design: Karen Fream EUG Legal: Barry Gerber Email: brandstandards@eur.ko.com</p> <p>EAG Brand: Sedef Salingan Sahin EAG Design: Elif Tokat EAG Legal: Linda Spencer Email: brandstandards@afr.ko.com</p> <p>LatAm Brand: Cynthia Gonzalez LatAm Design: Guido Rosales LatAm Legal: Roxana Penagos Email: brandstandards@la.ko.com</p> <p>Pacific Brand: Shakir Moin Pacific Design: Shakir Moin Pacific Legal: Rachel Peterson Email: brandstandards@apac.ko.com</p> <p>Japan Brand: Santiago Bargagna Japan Design: Hide Matsunaga Japan Legal: Hirotochi Adachi Email: brandstandards@apac.ko.com</p> <p>NA Brand: Caren Pasquale Seckler NA Design: Frederic Kahn NA Legal: Jim Dudukovich/Pamela Mallari Email: brandstandards@na.ko.com</p>		

